



— Installation assistance available at: —

RFTECH

— www.rockfordfosgate.com/support —

2014+
HARLEY-DAVIDSON®
STREET/ ROAD GLIDE
AMPLIFIER INSTALL KIT

RFK-HD14M5

Save Your Speakers!

Download our free Amp Tuning Guide by searching "Tuning Guide" from www.rockfordfosgate.com/support

If using a factory radio, you must get it flashed. Find dealers that flash at www.rockfordfosgate.com/dealerlocator

600 South Rockford Drive • Tempe, Arizona 85281 United States
Direct: (480) 967-3565 • Toll Free: (800) 669-9899

rockfordfosgate.com

Installation & Operation

Introduction

Dear Customer,

Congratulations on your purchase of the world's finest brand of audio products. At Rockford Fosgate we are fanatics about musical reproduction at its best, and we are pleased you chose our product. Through years of engineering expertise, hand craftsmanship and critical testing procedures, we have created a wide range of products that reproduce music with all the clarity and richness you deserve.

For maximum performance we recommend you have your new Rockford Fosgate product installed by an Authorized Rockford Fosgate Dealer. Please read your warranty and retain your receipt and original carton for possible future use.

Great product and competent installations are only a piece of the puzzle when it comes to your system. Make sure that your installer is using 100% authentic installation accessories from Rockford Fosgate in your installation. Rockford Fosgate has everything from RCA cables and speaker wire to power wire and battery connectors. Insist on it! After all, your new system deserves nothing but the best.

To add the finishing touch to your new Rockford Fosgate image order your Rockford accessories, which include everything from T-shirts to hats.

Visit our web site for the latest information on all Rockford products; www.rockfordfosgate.com or, in the U.S. call 1-800-669-9899. For all other countries, call +001-480-967-3565.

Table of Content

- 2 Introduction
- 3-7 Contents
- 8 Warranty

If, after reading your manual, you still have questions regarding this product, we recommend that you see your Rockford Fosgate dealer. If you need further assistance, you can call us direct at 1-800-669-9899. Be sure to have your serial number, model number and date of purchase available when you call.

For the latest information and installation instructions go to <https://rockfordfosgate.com/products/selector/motorcycle-accessories/>

Installation Considerations

This section focuses on some considerations for installing your motorcycle amplifier installation kit. This manual will show you all of the parts that are included in the kit. This kit works on all 2014 to present Road Glide®, Street Glide® including Ultra's and CVO's not factory equipped with "Harley Davidson® powered by Rockford Fosgate".

If you feel unsure about installing the system yourself, reach out to a qualified technician. You can locate one close to you by going to www.rockfordfosgate.com/dealerlocator

Before installation, disconnect the battery negative (-) terminal to prevent damage to the unit, fire and/or possible injury.

PRACTICE SAFE SOUND

Continuous exposure to sound pressure levels over 100dB may cause permanent hearing loss. High powered auto sound systems may produce sound pressure levels well over 130dB. Use common sense and practice safe sound.

PRATIQUEZ UNE ÉCOUTE SANS RISQUES

Une exposition continue à des niveaux de pression acoustique supérieurs à 100 dB peut causer une perte d'acuité auditive permanente. Les systèmes audio de forte puissance pour auto peuvent produire des niveaux de pression acoustique bien au-delà de 130 dB. Faites preuve de bon sens et pratiquez une écoute sans risques

PRACTIQUE EL SONIDO SEGURO

El contacto continuo con niveles de presión de sonido superiores a 100 dB puede causar la pérdida permanente de la audición. Los sistemas de sonido de alta potencia para automóviles pueden producir niveles de presión de sonido superiores a los 130 dB. Aplique el sentido común y practique el sonido seguro.

PRAKTIZIEREN SIE SICHEREN SOUND

Fortgesetzte Geräuschdruckpegel von über 100 dB können beim Menschen zu permanentem Hörverlust führen. Leistungsstarke Autosoundsysteme können Geräuschdruckpegel erzeugen, die weit über 130 dB liegen. Bitte wenden Sie gesunden Menschenverstand an und praktizieren Sie sicheren Sound.

OSSERVATE LE REGOLE DEL SUONO SENZA PERICOLI

La costante esposizione a livelli di pressione acustica al di sopra dei 100dB possono causare la perdita permanente dell'udito. I sistemi audio ad alta potenza possono produrre livelli di pressione acustica ben superiori ai 130dB. Si consiglia il buon senso e l'osservanza delle regole del suono senza pericoli

Be sure to carefully read and understand the instructions before attempting to install this motorcycle audio kit.

Consult your motorcycle's service manual for model specific information. Models may differ from year to year depending on factory options and aftermarket accessories added.

This motorcycle amplifier installation kit is specifically designed to work with Rockford Fosgate's M5-800X4 amplifier in both 2 or 4-channel configurations.

With the addition of an amplifier, be sure that your current charging system is in proper working order.

Utilize a blanket or fender cover to protect the front fender from tools or any other items that may be accidentally dropped while removing the fairing.

Visit rockfordfosgate.com/support for more comprehensive installation videos and product information.

Contents

- (1) Power Harness
- (1) H-D® Radio T-Harness
- (1) Road Glide® 90° Power Input Harness
- (2) Speaker Output Y-Adapter
- (2) Boom!™ amp Bypass Harness
- (1) CVO 6 Speaker bypass (left)
- (1) CVO 6 Speaker bypass (right)
- (8) Wire Zip Tie Wraps

- (4) Amp Mounting Screws
- (1) Road Glide® Amp Mounting Brackets
- (2) Road Glide® Amp Bracket Nuts & Bolts
- (4) Road Glide® Heat Sink Screws
- (4) Street Glide® Heat Sink Screws
- (4) Street Glide® Heat Sink Stand-off's
- (1) Amp Heat Sink

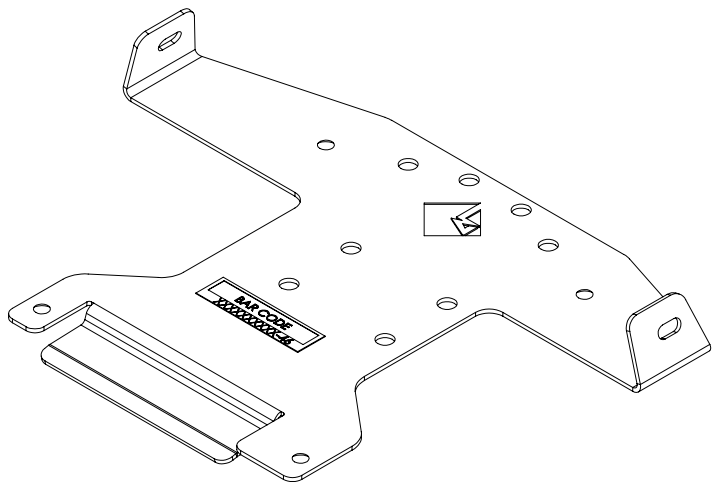
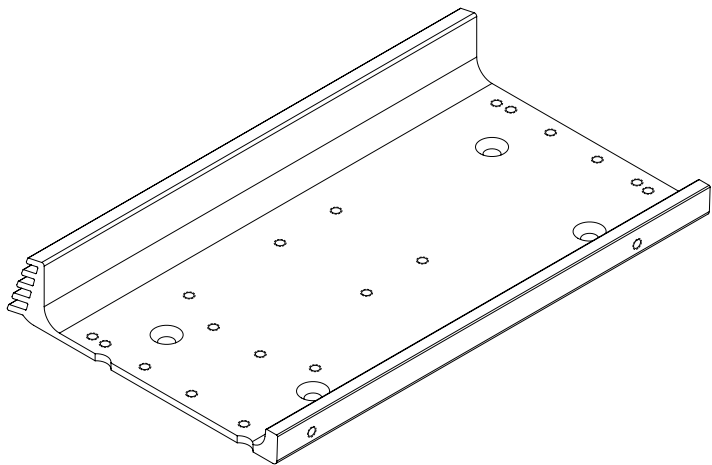

Contents

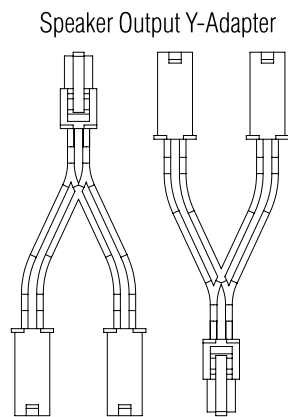
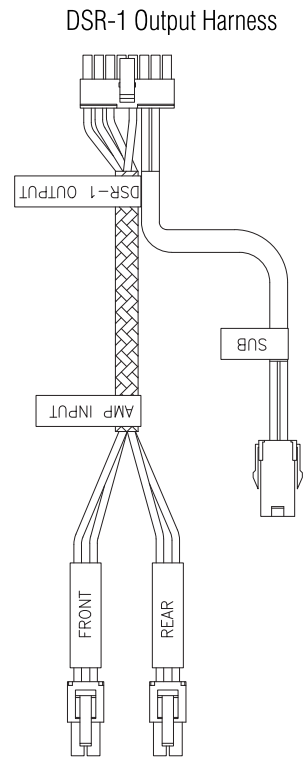
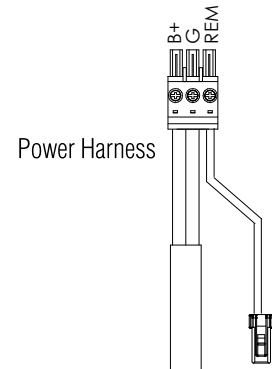
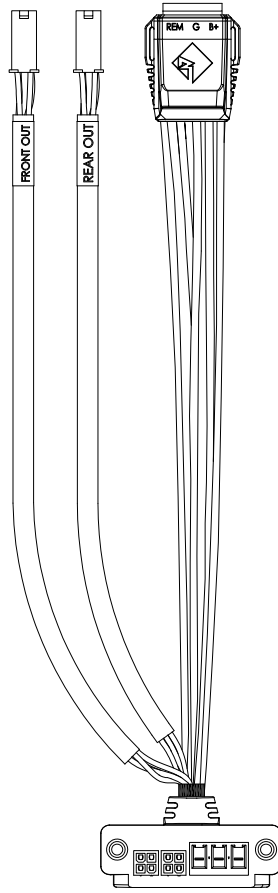
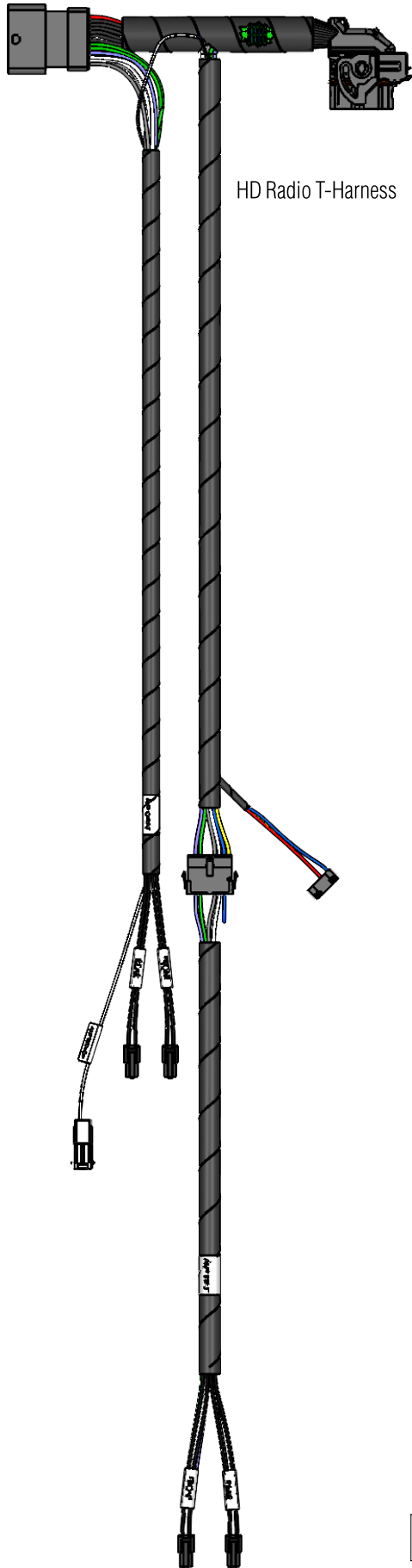

CVO Amp Bypass Adapters

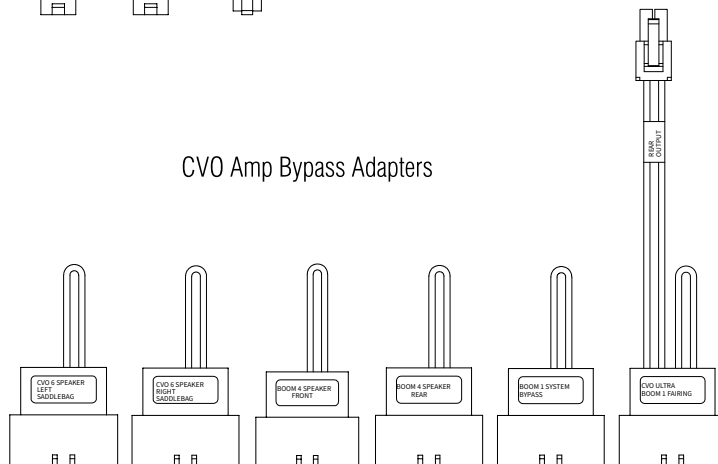

Warranty

Rockford Corporation offers a limited warranty on Rockford Fosgate products on the following terms:

Length of Warranty

POWER Amplifiers – 2 Years
BMW® Direct Fit Speakers – 2 Years
PUNCH® & PRIME® Amplifiers – 1 Year
Speakers, Signal Processors, Accessories and Capacitors – 1 Year
All marine, motorcycle, motorsport products - 2 Years
Any Factory Refurbished Product – 90 Days (receipt required)

What is Covered

This warranty applies only to Rockford Fosgate products sold to consumers by authorized Rockford Fosgate dealers in the United States of America. Products purchased by consumers from an Authorized Rockford Fosgate Dealer in another country are covered only by that country's Distributor and not by Rockford Corporation.

Who is Covered

This warranty covers only the original purchaser of Rockford product purchased from an authorized Rockford Fosgate dealer in the United States. In order to receive service, the purchaser must provide Rockford with a copy of the receipt stating the customer name, dealer name, product purchased and date of purchase.

Products found to be defective during the warranty period will be repaired or replaced (with a product deemed to be equivalent) at Rockford's discretion.

What is Not Covered

Damage caused by accident, abuse, improper installation, operations, theft, water (on non-Element Ready products).

Any cost or expense related to the removal or reinstallation of product.

Service performed by anyone other than Rockford or an authorized Rockford Fosgate service center.

Any product which has had the serial number defaced, altered, or removed.

Subsequent damage to other components.

Any product purchased outside the U.S.

Any product not purchased from an authorized Rockford Fosgate dealer. Refer to rockfordfosgate.com dealer locator for more detail.

Limit on Implied Warranties

Any implied warranties including warranties of fitness for use and merchantability are limited in duration to the period of the express warranty set forth above. Some states do not allow limitations on the length of an implied warranty, so this limitation may not apply. No person is authorized to assume for Rockford Fosgate any other liability in connection with the sale of the product.

How to Obtain Service

Please call 1-800-669-9899 for Rockford Customer Service. You must obtain an RA# (Return Authorization number) to return any product to Rockford Fosgate. You are responsible for shipment of product to Rockford.

EU Warranty

This product meets the current EU warranty requirements, see your Authorized dealer for details.