

For information about other American International automotive accessories visit our website at:

<http://www.aius.net>

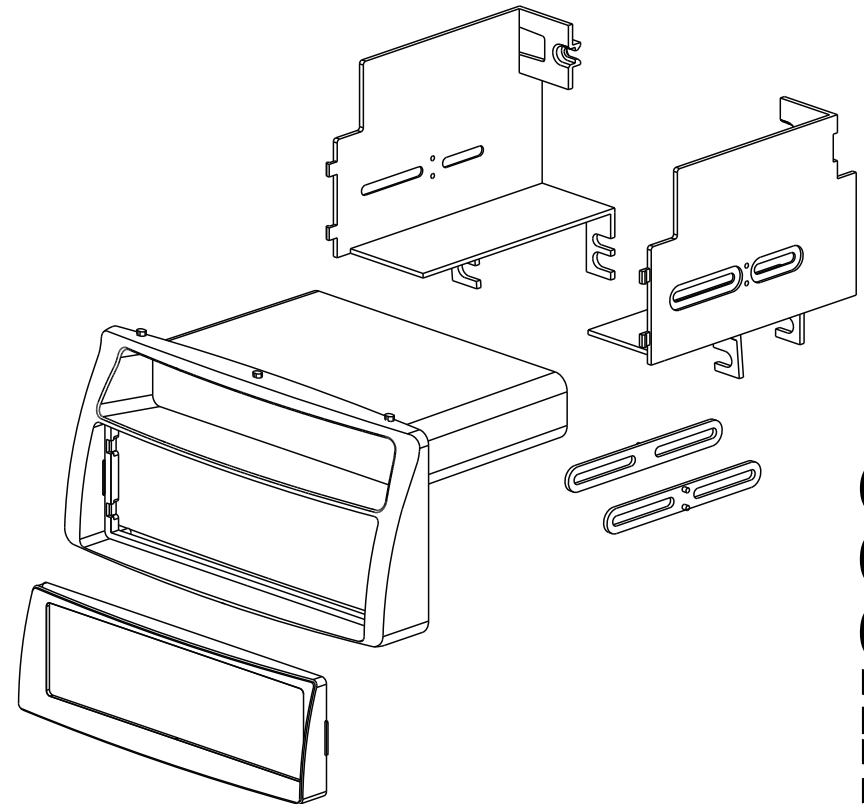

**American
International**
Car Stereo Installation Kits & Accessories



TOYK960 Mounting Kit



American International

WWW.AIUS.NET

2500 East Francis Street Ontario, CA 91761, U.S.A.

USA Sales (800) 336-6500

Canada Sales (888) 922-3006

CUSTOMER HELP LINE

USA 800-323-4329 • Canada 800-245-8777

IT0YK960

VEHICLE APPLICATIONS

Toyota
2003-08 COROLLA

DASH DISASSEMBLY INSTRUCTIONS

1. Carefully remove the trim around the shift lever (unscrew shift knob for manual shift vehicles).
2. Carefully pull on the middle climate control knob and remove. Remove the (1) phillips screw from this location.
3. Carefully pry the climate controls and pocket assembly forward, disconnect all harnesses and remove assembly.
4. Remove the (4) 10mm bolts securing the factory radio to the sub-dash.
5. Carefully pry Radio/Vent assembly forward, disconnect all harnesses and antenna lead end remove assembly.
6. Carefully remove radio from Vent assembly.

DIN MOUNT INSTALLATION INSTRUCTIONS

1. Insert DIN sleeve from your new radio into the radio opening of the installation kit.
2. Depress the tabs from inside the sleeves opening upward, outward, and downward to secure metal sleeve to the installation kit.

INSERT LEFT AND RIGHT MOUNTING BRACKETS INTO RADIO OPENING AS SHOWN BELOW AND SECURE TO BACK OF POCKET USING SCREWS PROVIDED

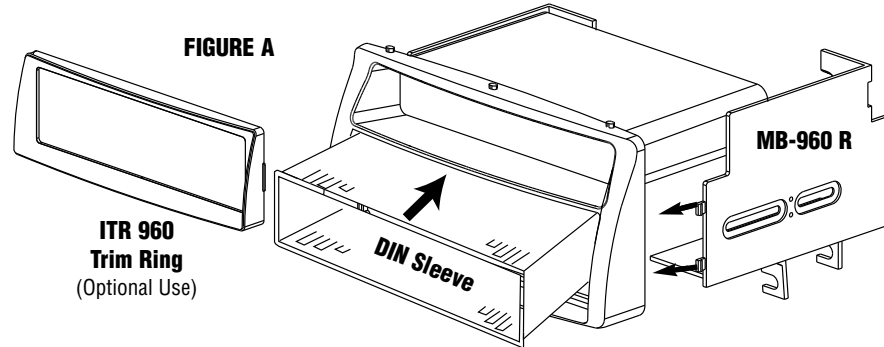

NOTE: POCKET MUST BE ON TOP

ISO MOUNT INSTALLATION INSTRUCTIONS

1. Attach ISO brackets to the rear of the main mounting kit (see Fig. B).
2. Insert spacers into brackets on both sides only when ISO mounting radio (see Fig. C).
3. Slide radio into kit from rear & attach to ISO mounting brackets using screws supplied with radio (do not tighten screws at this time).
4. Slide radio forward or backward for your desired look and then tighten the mounting screws. Use ISO trim ring when possible.
5. Attach rear support strap (supplied with radio) to rear of pocket and to rear of radio.

INSERT LEFT AND RIGHT MOUNTING BRACKETS INTO RADIO OPENING AS SHOWN BELOW AND SECURE TO BACK OF POCKET USING SCREWS PROVIDED

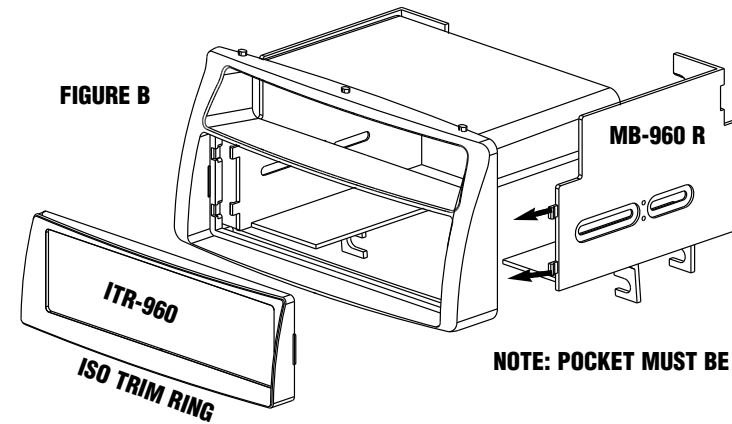

NOTE: POCKET MUST BE ON TOP

FOR ISO MOUNT APPLICATIONS

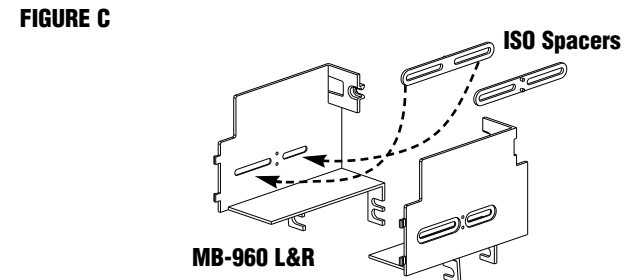

INSERT SPACERS INTO BRACKETS ON BOTH SIDES ONLY WHEN ISO MOUNTING RADIO