

Wiring

1. **RADIOS ONLY** - Follow wiring instructions supplied with radio. Test radio / speakers. If you wish to keep the factory wiring intact, a wiring harness may be purchased. (American International Part # NW-H700).
2. **RADIOS AND EQUALIZERS** - Follow wiring instructions supplied with radio and equalizer. Test radio / speakers. If you wish to keep the factory wiring intact, a wiring harness may be purchased. (American International Part #NW-H700).

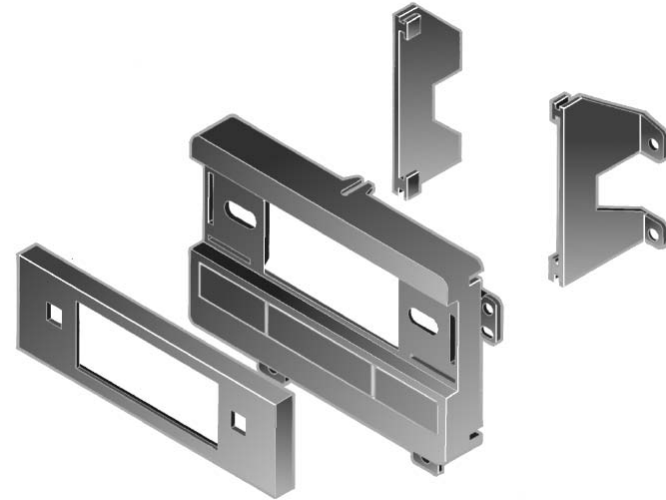

**American
International**
Car Stereo Installation Kits & Accessories



American International

Automotive Products Division

1040 Avenida Acaso • Camarillo, CA 93012, U.S.A.

USA Sales (800) 336-6500

Canada Sales (888) 922-3006 • USA Fax (805) 388-7950

For information about other American International automotive accessories visit our website at:

<http://www.americaninternational.net>

CUSTOMER HELP LINE

USA 800-323-4329 • Canada 800-245-8777

iNDK710

VEHICLE APPLICATIONS

Nissan

1989-94	240 SX
1993-97	ALTIMA
1990-92	STANZA

ND-K710 Mounting Kit

DASH DISASSEMBLY INSTRUCTIONS

1. Unsnap trim bezel.
2. Remove (4) screws securing radio assembly.
3. Remove radio assembly.
4. Disconnect all wires.

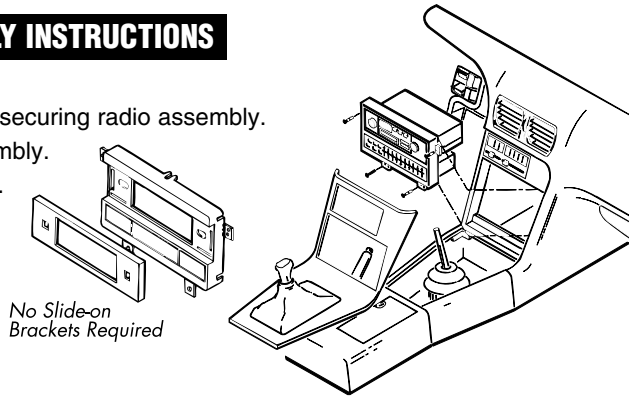

DASH DISASSEMBLY INSTRUCTIONS

1. Unsnap cover surrounding shifter.
2. Remove (2) screws in front of shifter and (2) screws above radio.
3. Remove (2) screws on bottom of steering wheel housing. Unsnap to locate (4) screws on right of steering wheel.
4. Remove radio assembly.
5. Remove radio from metal assembly, leave dish tray.

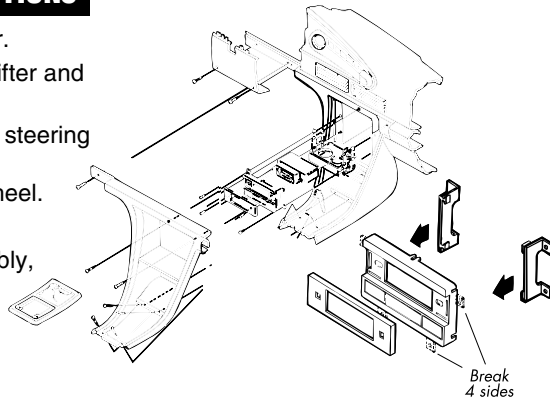

DASH DISASSEMBLY INSTRUCTIONS

1. Remove ashtray, and remove (2) screws above ashtray.
2. Remove (2) screws below A/C controls.
3. Remove (1) screw on right of steering column.
4. Remove (2) screws left of steering column.
5. Unsnap entire dash trim.
6. Disconnect hazard/defogger/panel light dimmer switch.
7. Remove dash trim.
8. Remove (4) screws securing radio assembly.
9. Remove radio assembly.
10. Disconnect all wires.

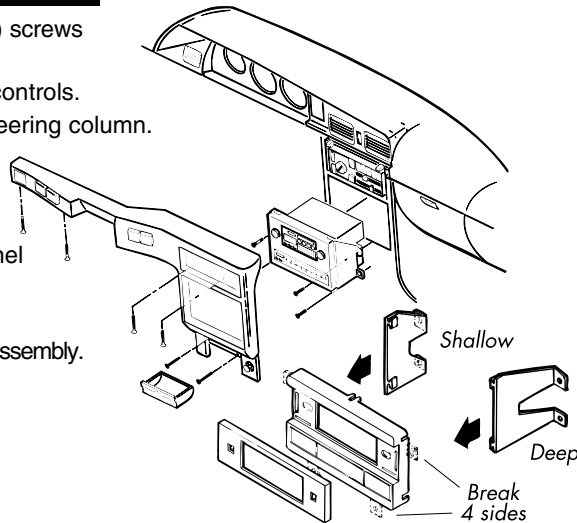

KIT ASSEMBLY INSTRUCTIONS

Shaft Radios

1. Compare radio shaft space to shaft opening in kit faceplate. Use screwdriver or nutdriver to snap out the necessary opening. (See Fig. 1)
2. Mount radio to kit / faceplate using knobs, trimplate, shaftnuts, washers, and spacers supplied with radio. Adjust the noseplate so it is flush with the front of the trimpanel. (See Fig. 2)

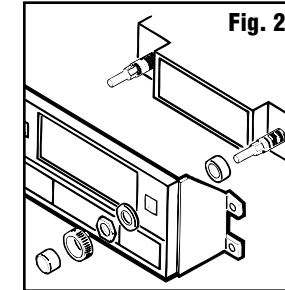
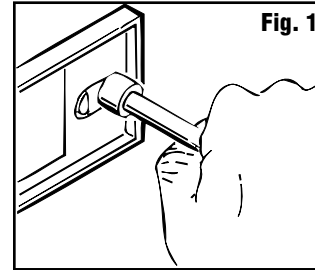

DIN Radios

1. Remove areas indicated in Fig. 3 by using side cutters to cut thru top and bottom segments to break away remaining area.
2. Follow radio mounting procedure using parts and instructions supplied with radio. (See Fig. 4)

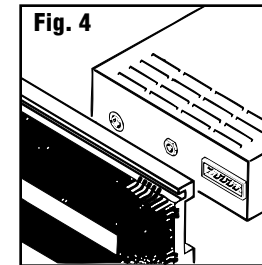
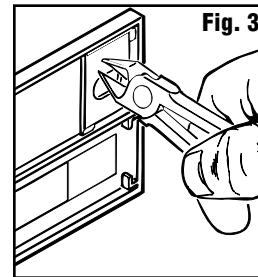

Equalizers

***NOTE:** If an equalizer is not being used, snap trimplate into place and proceed to wiring instructions.

1. Place equalizer into opening and secure to mounting frame using hardware supplied with equalizer. (See Fig. 5)

Rear Support

1. Use rear support strap supplied with radio to attach the rear of the radio / top slot of kit or in the dash cavity. (See Fig. 5)

