

For information about other American International automotive accessories visit our website at:

<http://www.americaninternational.net>

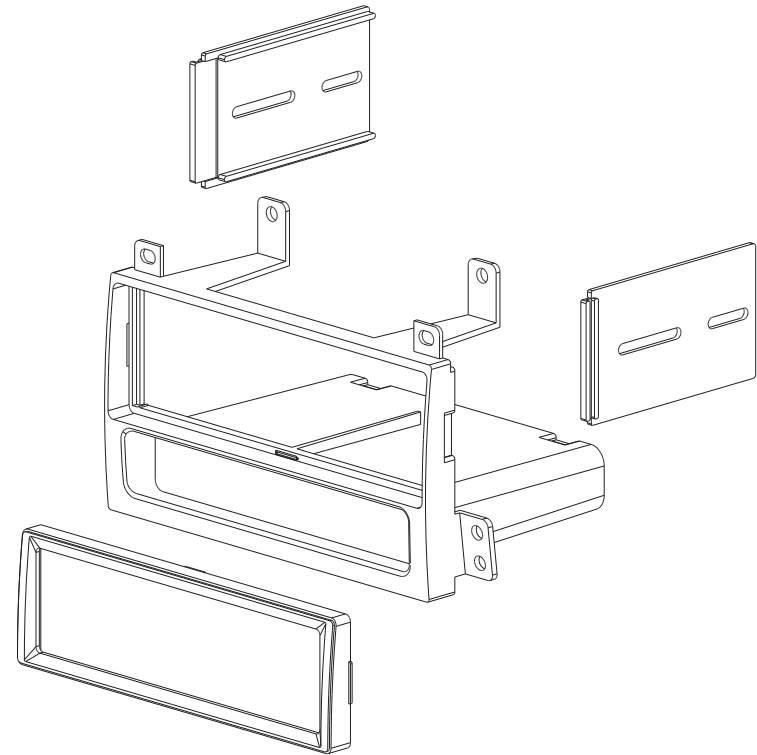

**American  
International**  
Car Stereo Installation Kits & Accessories



**LTC-K588 Mounting Kit**



**American International**

**Automotive Products Division**

1040 Avenida Acaso • Camarillo, CA 93012, U.S.A.

USA Sales (800) 336-6500

Canada Sales (888) 922-3006 • USA Fax (805) 388-7950

**VEHICLE APPLICATIONS**

**Lincoln**  
2003-08 TOWN CAR

**CUSTOMER HELP LINE**  
USA 800-323-4329 • Canada 800-245-8777

## DASH DISASSEMBLY INSTRUCTIONS

1. Set the emergency brake.
2. Remove the (2) 9/32 screws located above the instrument gauges.
3. Lower the steering column all the way down.
4. Place key in ignition and turn to the on position (DO NOT START CAR)!
5. Carefully pry outward on the entire dash trim bezel.
6. Disconnect the wire harnesses from the rear of the trim bezel's switches and remove the bezel.
7. Remove the (2) 9/32 screws securing the factory clock to the sub-dash, pry clock forward, disconnect the wire harness and remove clock.
8. Remove the (4) 9/32 screws securing the factory radio to the sub-dash.
9. Pull the radio forward, disconnect the wire harnesses and antenna lead and remove radio.

## DIN MOUNT INSTALLATION INSTRUCTIONS

1. Insert DIN sleeve from your new radio into the radio opening of the installation kit.
2. Depress the tabs from inside the sleeves opening upward, outward, and downward to secure sleeve to the installation kit.

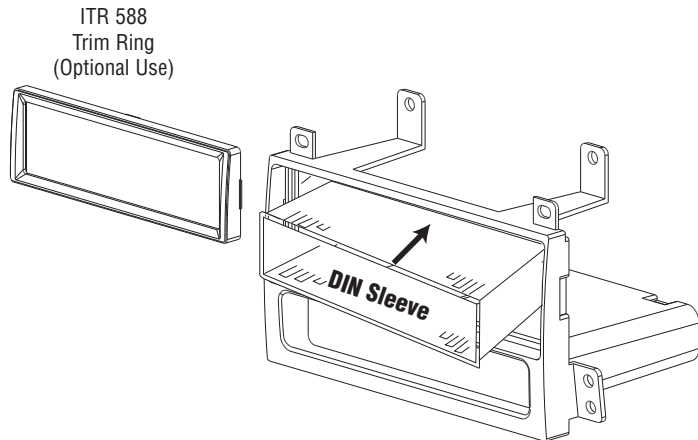

## ISO MOUNT INSTALLATION INSTRUCTIONS

1. Attach ISO brackets to the rear of the main mounting kit (see illustration above).
2. Slide radio into kit from rear & attach to ISO mounting brackets using screws supplied with radio (do not tighten screws at this time).
3. Slide radio forward or backward for your desired look and then tighten the mounting screws. Use ISO trim ring when possible.
4. Attach rear support strap (supplied with radio) to rear of pocket and to rear of radio.

