

For information about other American International automotive accessories visit our website at:

<http://www.americaninternational.net>

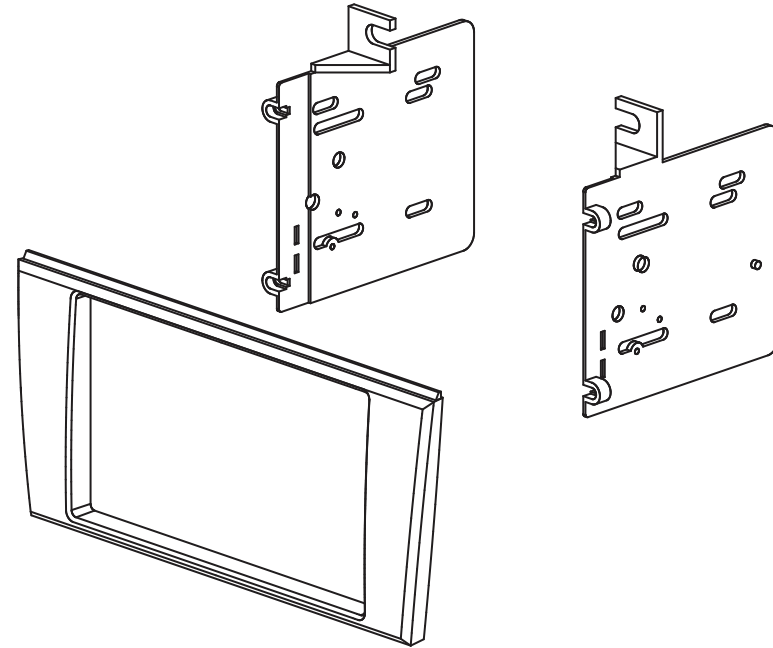

**American
International**
Car Stereo Installation Kits & Accessories



LLSK582 Mounting Kit

VEHICLE APPLICATIONS

Lincoln

2000-06 LS

Ford

2002-05 THUNDERBIRD

Automotive Products Division

1040 Avenida Acaso • Camarillo, CA 93012, U.S.A.

CUSTOMER HELP LINE

8am-4:30 P.S.T. Monday-Friday Except Holidays

USA 800-323-4329 • Canada 800-245-8777

iLLSK582

DASH DISASSEMBLY INSTRUCTIONS

1. Gently pry outward on the upper heater, A/C vents above the radio and remove.
2. Remove the (2) 5/16 bolts securing the top of the radio/climate control assembly to the sub-dash.
3. Gently pry outward on the top edges of the trim around the ashtray and remove.
4. Remove the (2) 9/32 bolts securing the ashtray assembly or 12V receptacle panel. Carefully slide the ashtray assembly outward, disconnect the lighter harness and remove the assembly.
5. Remove the (2) 5/16 bolts at the bottom of the radio/climate control assembly.
6. Carefully pull the radio/climate control assembly forward, disconnect all harnesses from the radio and climate controls and remove the assembly.
7. Remove the (6) 4mm or (6) #8 torx screws securing the factory radio to the assembly and remove the radio from the assembly.

KIT ASSEMBLY INSTRUCTIONS

1. Attach the left and right brackets in the kit to the rear of the kit face using the hardware supplied in the kit (4) small phillips screws.
2. Place the Double DIN radio between the left & right mounting brackets & slide the radio forward or back for best look & secure the radio to the brackets using (8) screws supplied with new radio or kit.
3. Remove the 3 locator posts on the top of the climate controls to allow the kit to rest flush on top of the climate controls (See Figure A below).
4. Loosen the top (2) phillips screws on the side of the climate control module.
5. Place the kit on top of the Climate controls, between the factory brackets.
6. Secure the kit to the factory brackets using (2) small screws supplied with kit. (See illustration below or on page 3 for your bracket setup.)
7. Make sure the front locator tabs from the left and right mounting brackets are in the correct holes on the factory brackets. (See illustration below or page 3).
8. Tighten climate control screws.

Figure A

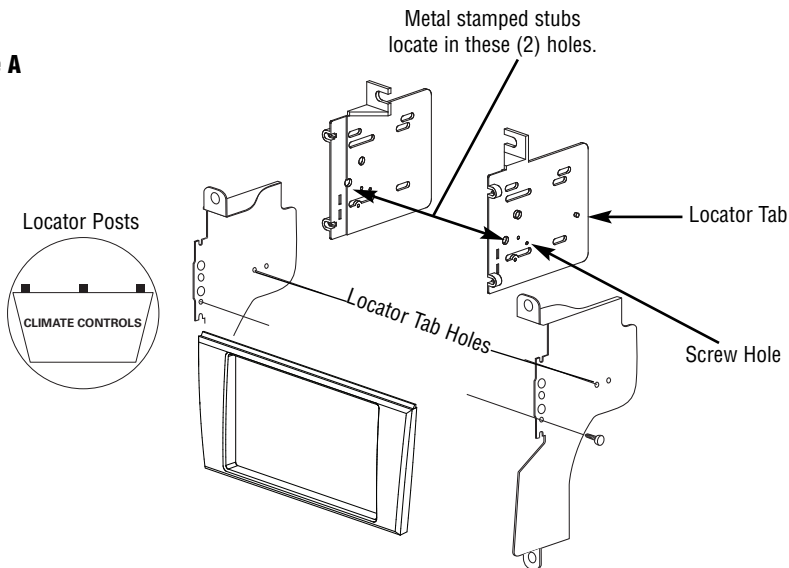

KIT ASSEMBLY INSTRUCTIONS

Figure A

