

For information about other American International automotive accessories visit our website at:

<http://www.americaninternational.net>

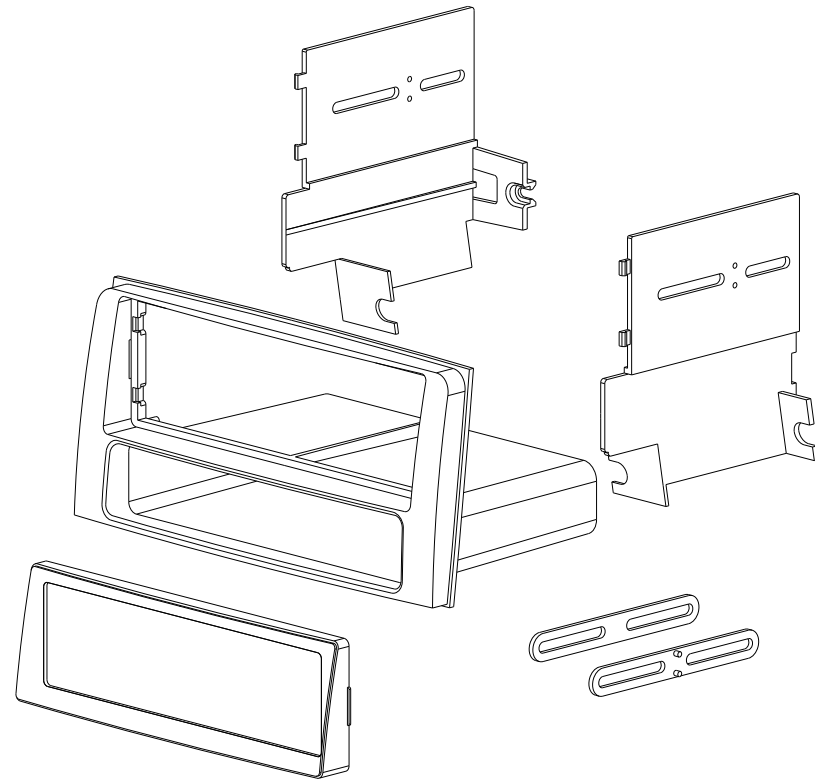

**American
International**
Car Stereo Installation Kits & Accessories



TOY-K962 Mounting Kit



American International

Automotive Products Division

1040 Avenida Acaso • Camarillo, CA 93012, U.S.A.

USA Sales (800) 336-6500

Canada Sales (888) 922-3006 • USA Fax (805) 388-7950

VEHICLE APPLICATIONS

Toyota

2003-09

4 RUNNER LIMITED EDITION

2003-09

4 RUNNER SPORT EDITION with RDS RADIO

CUSTOMER HELP LINE

USA 800-323-4329 • Canada 800-245-8777

IT0YK962

DASH DISASSEMBLY INSTRUCTIONS

1. Open the center pocket below the climate controls and remove the (1) 10 mm bolt.
2. Open the Center console rear pocket lid.
3. Carefully Unclip the forward part of the center console section with ashtray trim, disconnect the harness and remove console section.
4. Carefully unclip and remove the trim ring from around the key cylinder.
5. Carefully lift the center console side covering and remove.
6. Remove the (2) lower 10 mm bolts from the bottom of driver side under dash panel.
7. Carefully pull drivers side under dash panel outward and lay out of the way.
8. Remove the (1) 10mm bolt at the lower edge of the radio trim bezel on the driver side.
9. Unclip the trim from the front of the center console pocket.
10. Carefully pry outward the climate control pod, disconnect the wire harness and remove pod.
11. Remove the (2) 10mm bolts from behind the climate control location.
12. Carefully unclip the entire radio/climate control trim bezel, disconnect all harnesses from bezel and remove.
13. Remove the (2) 10mm bolts securing the factory radio to the sub-dash.
14. Carefully pull radio forward, disconnect all harnesses and antenna leads and remove radio.

DIN MOUNT INSTRUCTIONS

1. Attach mounting brackets to rear of kit as shown below and secure to rear of pocket using small screws provided with kit.
2. Insert DIN sleeve from your new radio into the opening of the installation kit.
3. Depress the tabs from inside the sleeves opening upward, outward, and downward to secure sleeve to the installation kit.

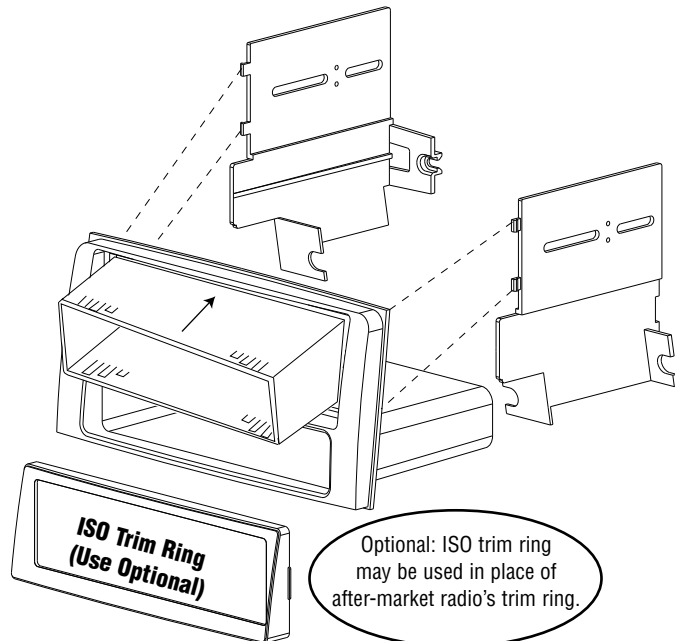

ISO MOUNT INSTRUCTIONS

1. Attach ISO mount brackets to rear of kit as shown below and attach to rear of pocket using small screws provided with kit.
2. Attach (1) ISO Spacer to the inside of both Left & Right mounting brackets as shown in Fig. A below.
3. Insert ISO mountable radio between ISO mount brackets and loosely attach to sides of radio using screws provided with radio when possible or screws supplied with kit.
4. Attach ISO trim ring to face of kit.
5. Slide radio forward or backward for desired look and tighten screws.

