

KIT ASSEMBLY INSTRUCTIONS

Two Single DIN or ISO Mount component Applications

1. Remove the Shaded tab from the bottom of each left and right mounting bracket (see Fig. B below).
2. Attach the left and right side brackets to the main bracket.
3. Attach climate controls to the top of the kit using existing screws.
5. Attach a rear support bracket to the rear of the radio components and adjust as needed to allow rear support bracket to rest in the sub-dash.

NOTE: Optional ISO trim ring (ITT-1300 and ITB-1300 included) may be used in place of after-market radio's trim rings. For ISO mount applications, mount after-market radio components to side brackets using hardware included.

For ISO mount only: Attach (1) ISO Spacer to the inside of upper & lower sections on both Left & Right mounting brackets as shown Fig. A.

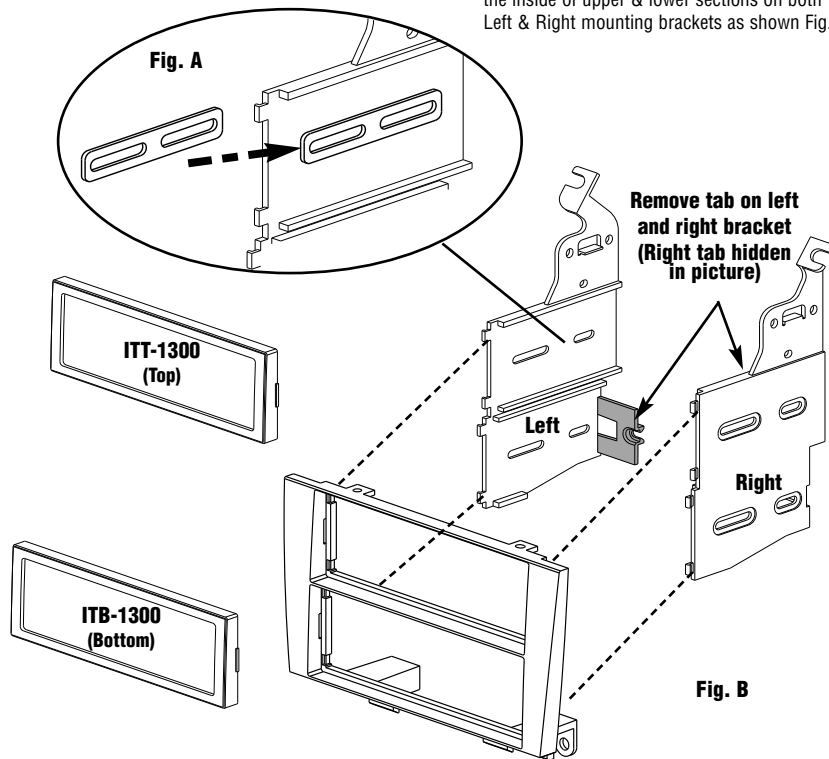

Automotive Products Division

1040 Avenida Acaso • Camarillo, CA 93012, U.S.A.

USA Sales (800) 336-6500

Canada Sales (888) 922-3006 • USA Fax (805) 388-7950

CUSTOMER HELP LINE

USA 800-323-4329 • Canada 800-245-8777



**American
International**
Car Stereo Installation Kits & Accessories



VEHICLE APPLICATIONS

Lexus

1992-96 LEXUS ES 300

LXS-K1300 Mounting Kit

DASH DISASSEMBLY INSTRUCTIONS

1. Using a panel removal tool, carefully unsnap and remove the vent above the Climate controls.
2. Remove the (2) 5/16 bolts securing the top of the Radio / Climate control brackets to the sub-dash.
3. Carefully unsnap and remove the trim at the bottom edge of the factory radio.
4. Remove the (2) 5/16 bolts securing the lower Radio / Climate control brackets to the sub-dash.
5. Make sure the ignition is turned off and set the parking brake.
6. Turn the key to the on position (not start) and move the shift lever all the way back.
7. Carefully pull the Radio / Climate control assembly forward.
8. Disconnect all harnesses and antenna leads from the Radio / Climate control assembly and remove the assembly from the vehicle.
9. Remove the (4) phillips screws securing the factory climate controls to the factory brackets and remove the climate controls from the assembly.

THIS KIT CONTAINS

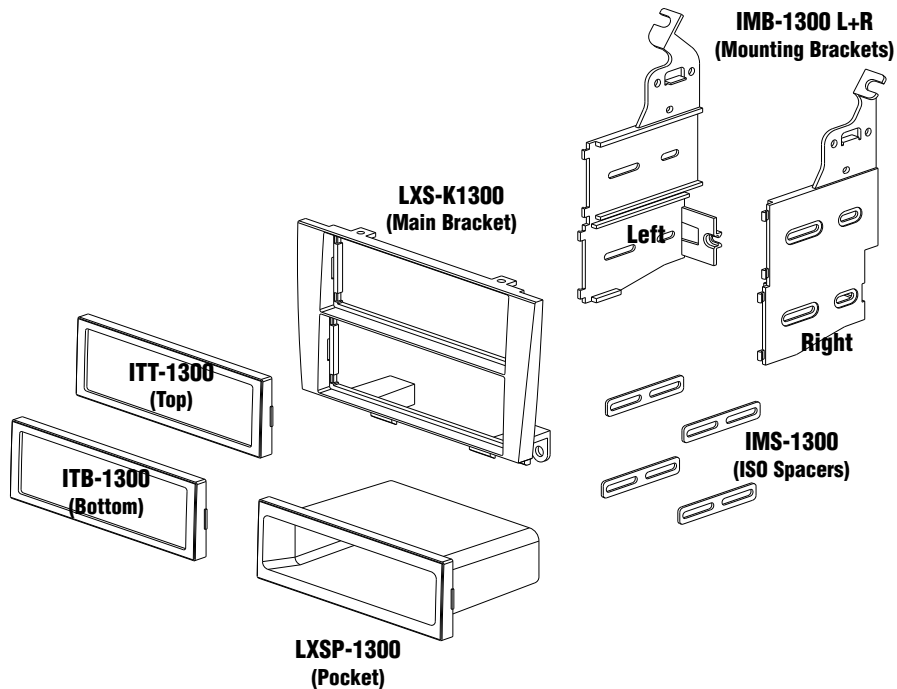

KIT ASSEMBLY INSTRUCTIONS

Single DIN & ISO Mount Applications

1. Attach the left and right side brackets to the main bracket.
2. Insert pocket into lower section of the main bracket.
3. Attach left and right side brackets to the rear of the pocket using screws supplied.
4. Attach climate controls to the top of the kit using existing screws.

DIN MOUNT INSTRUCTIONS

1. Insert DIN sleeve from your new radio into the upper section of the installation kit. (This DIN sleeve comes with all new radios and slides off the back of the radio)
2. Depress the tabs from inside the sleeves opening upward, outward, and downward to secure sleeve to the installation kit.
3. Install radio into sleeve and lock into place.
4. Support rear of radio with back strap.

NOTE: Optional ISO trim ring (ITT-1300 included) may be used in place of after-market radio's trim ring. For ISO mount applications, mount after-market radio to side brackets using hardware included.

