

For information about other American International automotive accessories visit our website at:

<http://www.aius.net>

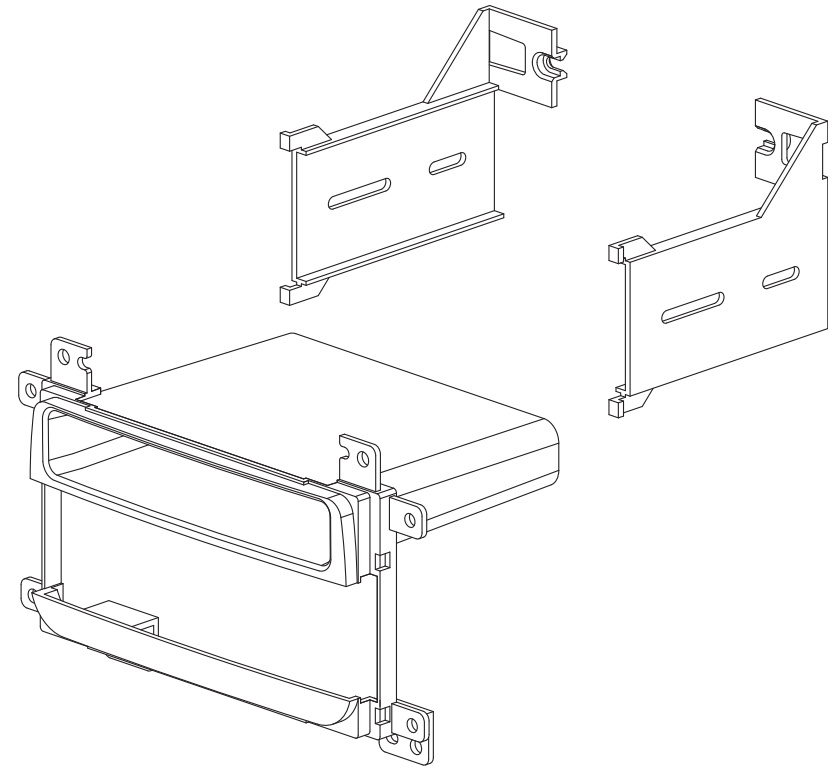

**American  
International**  
Car Stereo Installation Kits & Accessories



**SUZK946 Mounting Kit**



**American International**

**WWW.AIUS.NET**

2500 East Francis Street Ontario, CA 91761, U.S.A.

USA Sales (800) 336-6500

Canada Sales (888) 922-3006

**CUSTOMER HELP LINE**

**USA 800-323-4329 • Canada 800-245-8777**

iSUZK946

### VEHICLE APPLICATIONS

**Suzuki (ISO Mount Applications Only)**

2003-04 AERIO  
2003-05 GRAND VITARA  
2003-06 XL-7

## 2003-04 AERIO

### DASH DISASSEMBLY INSTRUCTIONS

1. Carefully pry radio trim bezel outward to remove.
2. Remove the (4) Phillips screws securing the radio to the sub-dash.
3. Pull radio forward, disconnect the wire harness and antenna lead and remove radio.

## 2003-05 GRAND VITARA / 2003-06 XL-7

### DASH DISASSEMBLY INSTRUCTIONS

1. Remove the (2) Phillips screws located under the front edge of the radio/climate control trim bezel.
2. Open the pocket from below the climate controls.
3. Remove the plastic cover attached to the bottom of the climate controls (the retaining clips are at the front of the panel, depress backwards to release cover).
4. Carefully remove all harnesses from the climate control module.
5. Carefully pry the radio/climate control trim bezel forward just enough to remove the plastic hose from the back of the trim bezel located on the lower right side.
6. Disconnect the harnesses from the back of the climate controls, and remove radio/climate control trim bezel.
7. Remove the (4) Phillips screws securing the factory radio to the sub-dash.
8. Pull radio forward, disconnect the wire harness and antenna lead and remove radio.

## KIT ASSEMBLY INSTRUCTIONS

### ISO MOUNT ONLY

1. Slide radio in from behind
2. Loosely attach ISO mountable radio to left and right bracket of kit using (4) flat head phillips screws supplied with kit or radio.
3. Slide radio forward or backwards for desired look and tighten mounting screws.

### KIT PREPARATION

Step 1.

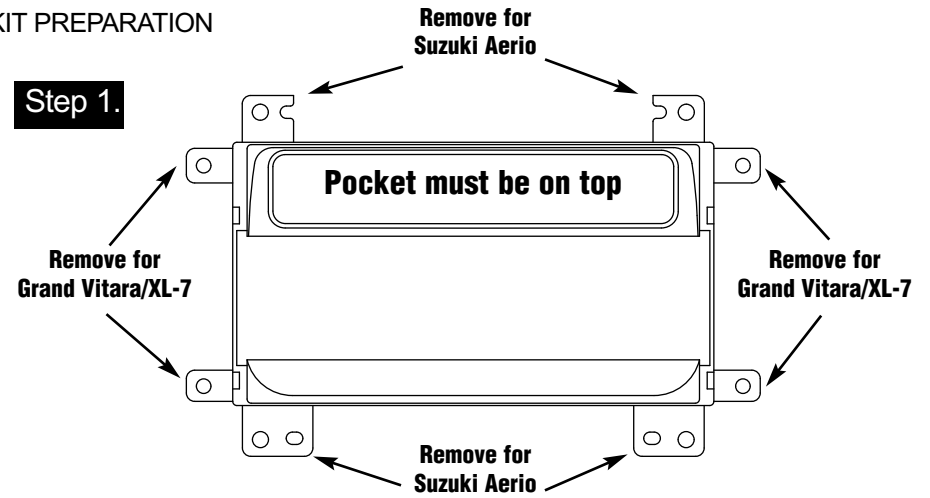

Step 2.

