

For information about other American International automotive accessories visit our website at:

<http://www.americaninternational.net>

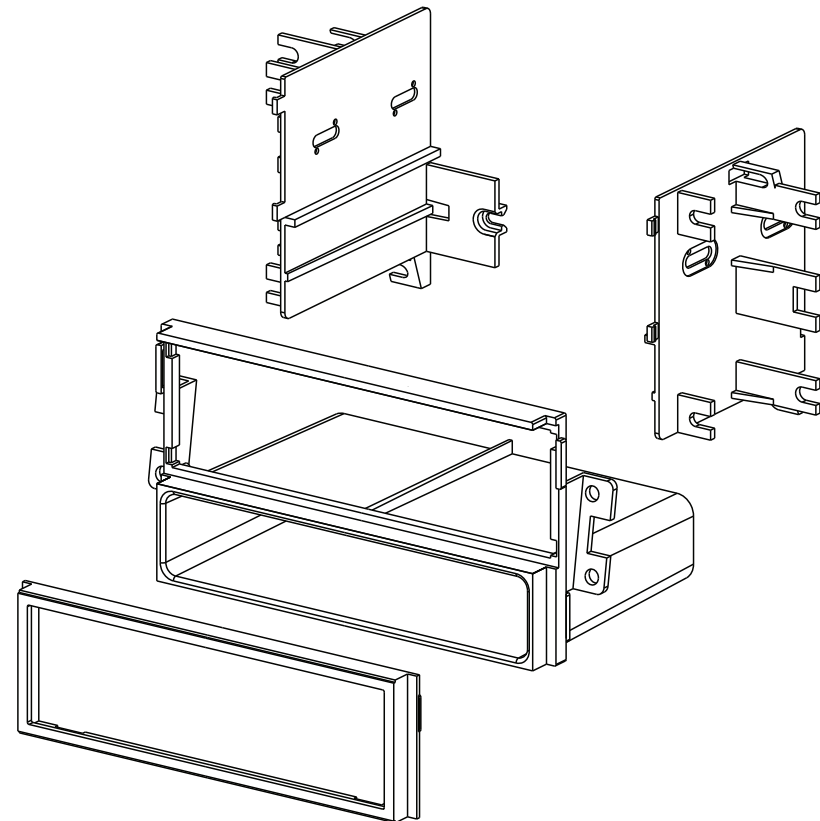

**American
International**
Car Stereo Installation Kits & Accessories



MITK890 Mounting Kit



American International

Automotive Products Division

1040 Avenida Acaso • Camarillo, CA 93012, U.S.A.

USA Sales (800) 336-6500

Canada Sales (888) 922-3006 • USA Fax (805) 388-7950

VEHICLE APPLICATIONS

Mitsubishi

1995-05 ECLIPSE

2000-04 MONTERO SPORT

2003-06 OUTLANDER

Eagle

1995-98 TALON

CUSTOMER HELP LINE

USA 800-323-4329 • Canada 800-245-8777

iMITK890

DASH DISASSEMBLY & RADIO REMOVAL INSTRUCTIONS

1. Remove the (2) Phillips screws from the trim bezel below the radio.
2. Gently lift upward from the bottom of the dash trim bezel and pull the top of the trim bezel towards you to release the (2) spring retaining clips.
3. Disconnect the hazard harness from the dash trim bezel and remove the trim bezel.
4. Remove the (4) Phillips screws securing the factory radio to the sub-dash.
5. Pull the radio forward, disconnect the harnesses and antenna lead and remove the radio.

KIT ASSEMBLY

FOR DIN & ISO MOUNT APPLICATIONS

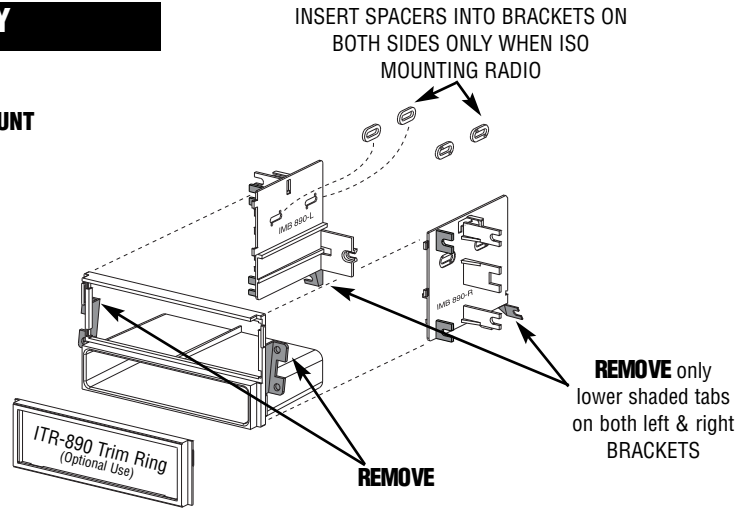

DASH DISASSEMBLY & RADIO REMOVAL INSTRUCTIONS

1. Carefully remove the trim bezel from around the radio using a panel removal tool.
2. Remove the (4) Phillips screws securing the radio to the sub-dash.
3. Carefully pull the radio forward, disconnect the wire harness and antenna leads and remove the radio.

KIT ASSEMBLY

FOR DIN AND ISO MOUNT APPLICATIONS

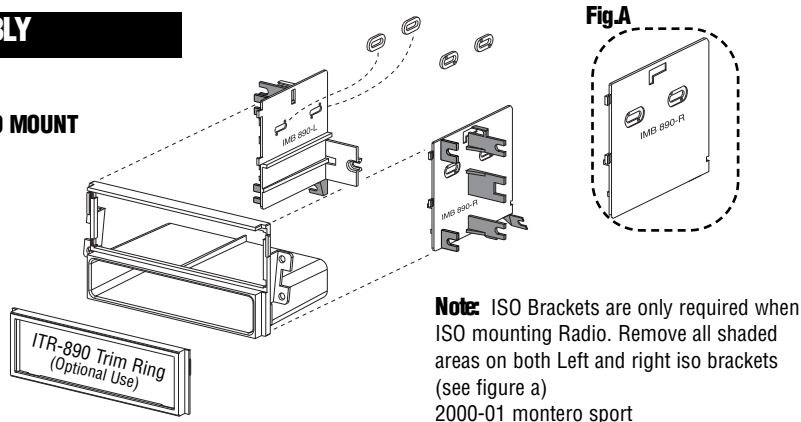

DASH DISASSEMBLY & RADIO REMOVAL INSTRUCTIONS

1. Carefully pull and remove the (3) knobs from the climate controls.
2. Remove the Phillips screws from each climate control knob location.
3. Carefully pry radio trim panel forward and remove trim.
4. Remove the (4) Phillips screws securing the factory radio to the subdash.
5. Carefully pull radio forward, disconnect the wire harness and antenna adapter and remove radio.

KIT ASSEMBLY

FOR DIN & ISO MOUNT APPLICATIONS

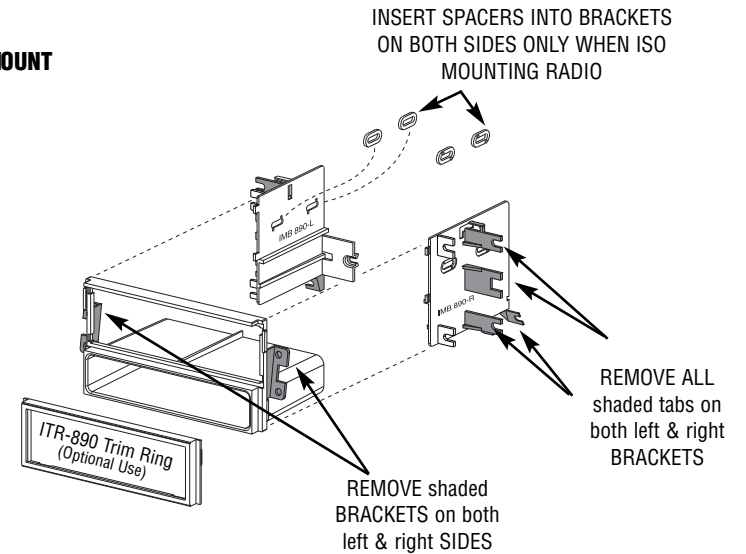

NOTES

DIN MOUNT INSTRUCTIONS

1. Insert DIN sleeve from your new radio into the upper section of the installation kit.
(This DIN sleeve comes with all new radios and slides off the back of the radio)
2. Depress the tabs from inside the sleeves opening upward, outward, and downward to secure sleeve to the installation kit.
3. Install radio into sleeve and lock into place.
4. Support rear of radio with back strap.

Optional use Trim Ring (ITR-890) may be used on some radios if desired.

Due to the movement of some faces on some radios our ISO Trim Ring may not be able to be used.

Your new radio must have a trim ring around the face of the radio that is designed to be easily removed. Consult your radio owner's manual.

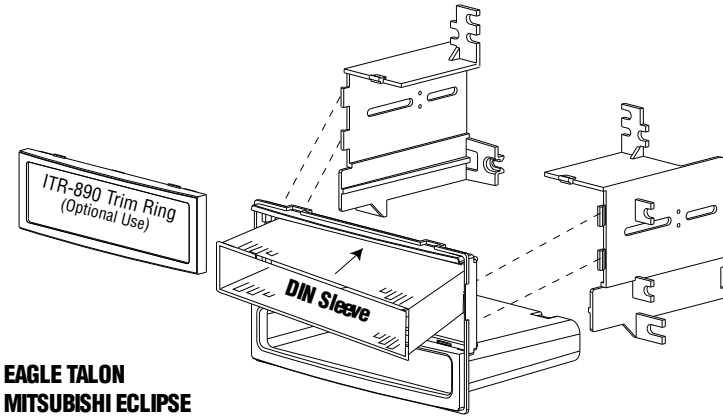

1995-98 EAGLE TALON
1995-99 MITSUBISHI ECLIPSE

KIT ASSEMBLY

FOR DIN AND ISO MOUNT
APPLICATIONS

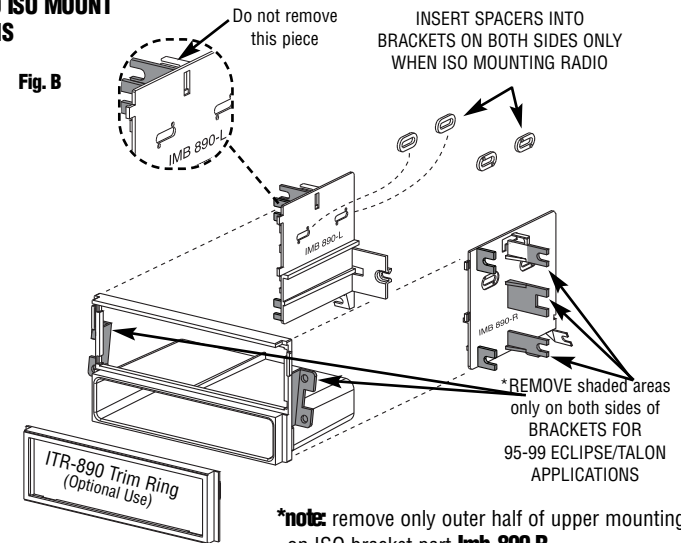

***note:** remove only outer half of upper mounting tab on ISO bracket part **Imb-890 R**

remove only the 3 parallel side mounting tabs on part **Imb-890 I** (See figure b)