

## DASH DISASSEMBLY INSTRUCTIONS

1. Gently pry outward on the upper heater, A/C vents above the radio and remove.
2. Remove the (2) 5/16 bolts securing the top of the radio/climate control assembly to the sub-dash.
3. Gently pry outward on the top edges of the trim around the ashtray and remove.
4. Remove the (2) 9/32 bolts securing the ashtray assembly, carefully slide the ashtray assembly outward, disconnect the lighter harness and remove the assembly.
5. Remove the (2) 5/16 bolts at the bottom of the radio/climate control assembly.
6. Carefully pull the radio/climate control assembly forward, disconnect all harnesses from the radio and climate controls and remove the assembly.
7. Remove the (6) 4mm screws securing the factory radio to the assembly and remove the radio from the assembly.

## KIT ASSEMBLY INSTRUCTIONS

1. Attach the left and right brackets in the kit to the rear of the pocket using the hardware supplied in the kit.
2. Remove the 3 locator posts on the top of the climate controls to allow the kit to rest flush on top of the climate controls (See Figure A).
3. Place the kit on top of the Climate controls, between the factory brackets.
4. Secure the kit to the factory brackets using (2) of the screws from the factory radio disassembly in step 7 above (see illustration below).
5. Make sure the rear locator tabs from the left and right mounting brackets are in the correct holes on the factory brackets.(see illustration below).

**NOTE:** Follow step 4 (above) for all models of radios excluding the factory 6-disc in-dash cd changer model. For factory 6-disc in-dash cd changer application use the front mounting holes on the side brackets (see illustration below).

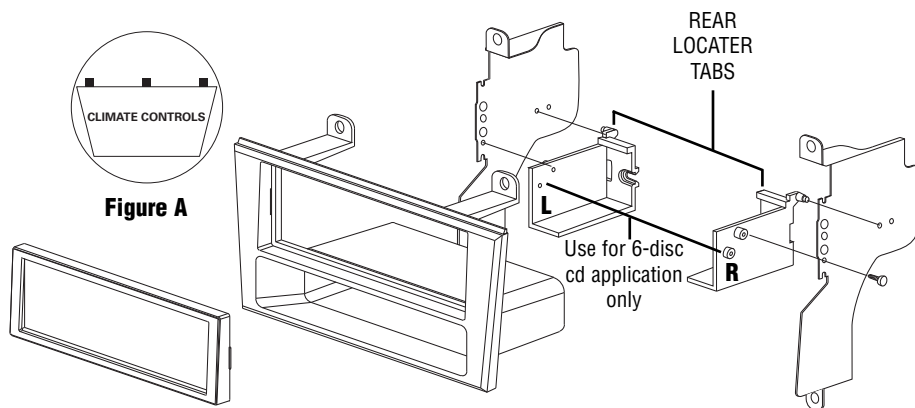

**American  
International**  
Car Stereo Installation Kits & Accessories

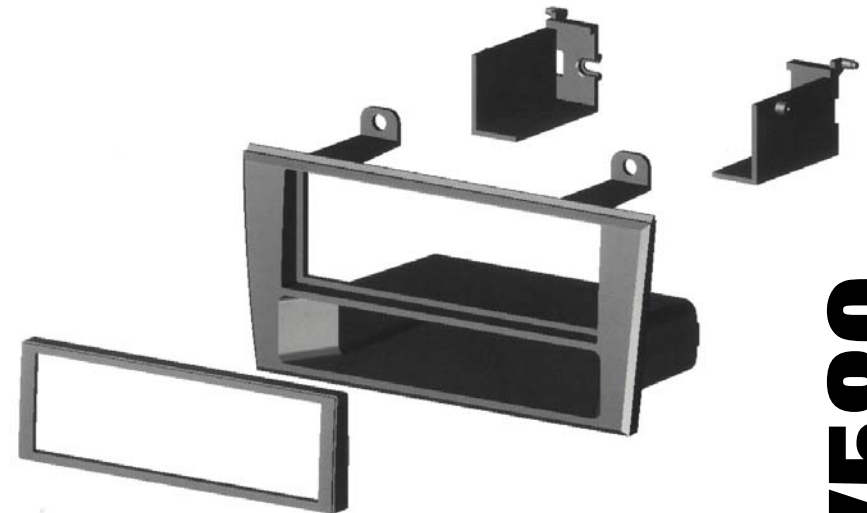

**LLS-K580 Mounting Kit**

## VEHICLE APPLICATIONS

**Lincoln**  
2000-06 LS  
**Ford**  
2002-05 THUNDERBIRD

**CUSTOMER HELP LINE**

USA 800-323-4329 • Canada 800-245-8777

iLLSK580