

For information about other American International automotive accessories visit our website at:

<http://www.americaninternational.net>

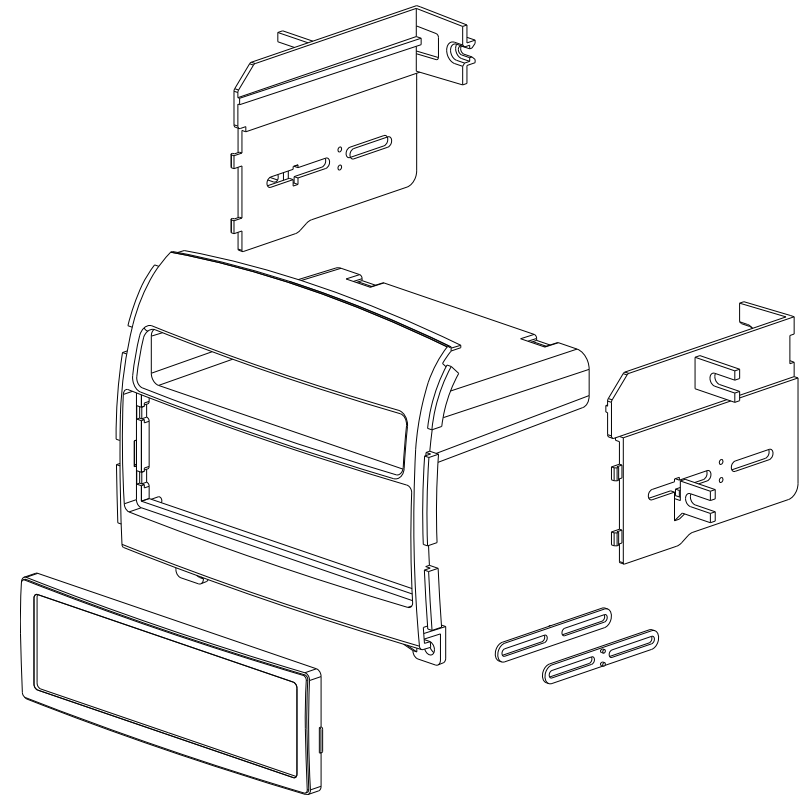

**American
International**
Car Stereo Installation Kits & Accessories



HYN-K1136 Mounting Kit



American International

Automotive Products Division

1040 Avenida Acaso • Camarillo, CA 93012, U.S.A.

USA Sales (800) 336-6500

Canada Sales (888) 922-3006 • USA Fax (805) 388-7950

CUSTOMER HELP LINE

USA 800-323-4329 • Canada 800-245-8777

iHYNK1136

VEHICLE APPLICATIONS

Hyundai
2006-08 SONATA

DASH DISASSEMBLY

1. Open the glove box, and remove the (2) phillips screws from the upper front edge of the glove box.
2. Carefully pry the thin curved dash trim panel outward and remove. (Note: This part goes from above the ignition key to above the glove box area).
3. Remove the (1) phillips screw securing the lower edges of each side trim located beside the radio.
4. Carefully pry these individual side trims forward to release. (Note: be sure to not loose the retainer clips). Disconnect the attached harnesses and remove trim pieces.
5. Remove the (2) phillips screws securing the lower edge of the factory radio to the sub-dash.
6. Remove the (4) phillips screws securing the radio to the sub-dash, pull radio forward, disconnect all wire harnesses and antenna lead and remove radio.

KIT ASSEMBLY INSTRUCTIONS

1. Attach the left and right side brackets to the main bracket.
2. Attach left and right side brackets to the rear of the pocket using small screws supplied with kit.

DIN MOUNT INSTRUCTIONS

1. Insert DIN sleeve from your new radio into the lower section of the installation kit. (This DIN sleeve comes with all new radios and slides off the back of the radio)
2. Depress the tabs from inside the sleeves opening upward, outward, and downward to secure sleeve to the installation kit.
3. Install radio into sleeve and lock into place.
4. Support rear of radio with back strap (supplied with radio).

Optional use Trim Ring (ITR-1136) may be used on some radios if desired.

Note: Some radio faces are larger in size than the ITR-1136 Trim Ring allows. You may need to file the Trim Ring opening larger for some radios.

Due to the movement of some faces on some radios our ISO Trim Ring may not be able to be used. You may also ISO mount your radio. See page 2.

Your new radio must have a trim ring around the face of the radio that is designed to be easily removed. Consult your radio owner's manual.

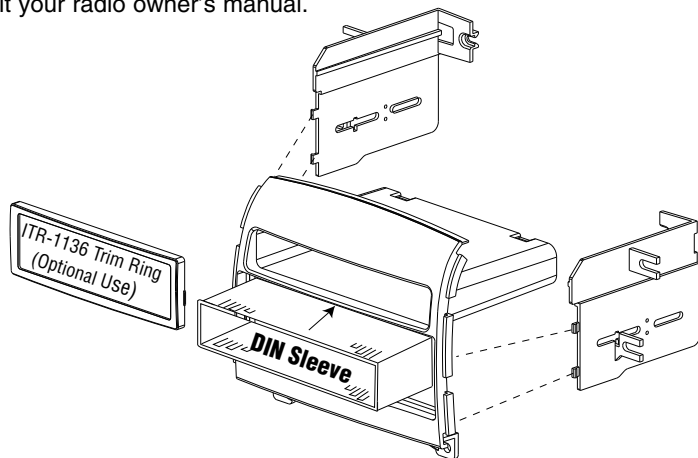

ISO MOUNT INSTALLATION INSTRUCTIONS

Note: Some radio faces are larger in size than the ITR-1136 Trim Ring allows. You may need to file the Trim Ring opening larger for some radios.

1. Attach the left and right side brackets to the main bracket. See illustration below.
2. Attach left and right side brackets to the rear of the pocket using screws supplied w/kit.
3. Attach ISO Mount Spacers to the inside of lower section on both Left & Right mounting brackets as shown in Figure A below.
4. Slide radio into kit from rear & attach to ISO mounting brackets using screws supplied with radio or screws supplied with kit (do not tighten screws at this time). Be sure the length of the screws DO NOT touch any electrical parts inside radio, some screws may need to be shortened.
5. Slide radio forward or backward for your desired look and then tighten the mounting screws. Use ISO trim ring when possible.
6. Attach rear support strap (supplied with radio) to rear of pocket and to rear of radio.

NOTE: Optional ISO trim ring (ITR-1136 included) may be used in place of after-market radio's trim ring.

Due to the movement of some faces on some radios our ISO Trim Ring may not be able to be used.

