

For information about other American International automotive accessories visit our website at:

<http://www.americaninternational.net>

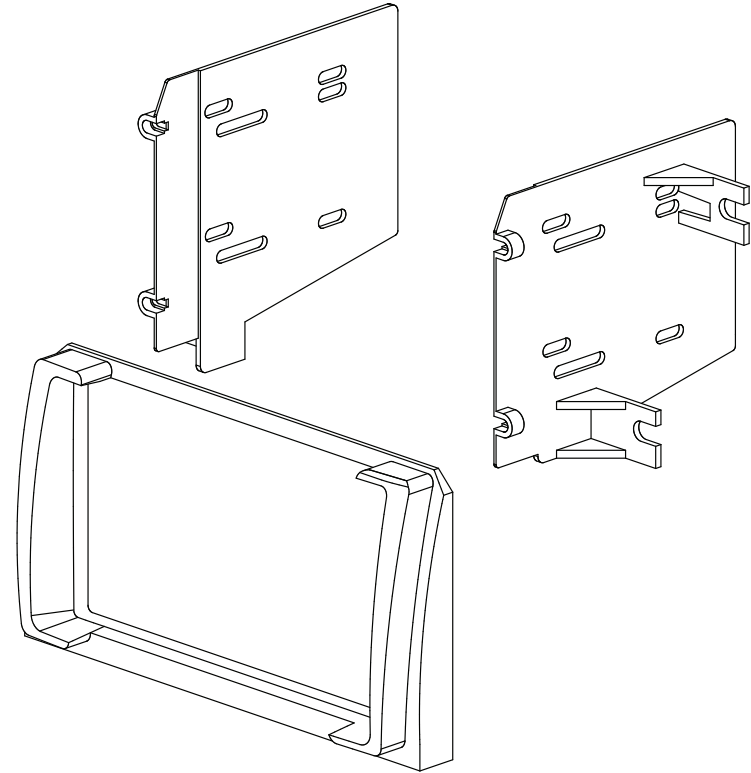

**American
International**
Car Stereo Installation Kits & Accessories



TOYK988 Mounting Kit



American International

Automotive Products Division

1040 Avenida Acaso • Camarillo, CA 93012, U.S.A.

USA Sales (800) 336-6500

Canada Sales (888) 922-3006 • USA Fax (805) 388-7950

CUSTOMER HELP LINE

8am-4:30 P.S.T. Monday-Friday Except Holidays

USA 800-323-4329 • Canada 800-245-8777

iTOYK988

VEHICLE APPLICATIONS

Pontiac

2009-10 VIBE

Toyota

2009-10 MATRIX

DASH DISASSEMBLY

1. Carefully pry radio/Climate control trim bezel forward, disconnect all harnesses attached to the rear and remove bezel.
2. Remove the (4) 10mm bolts securing the radio to the sub-dash.
3. Pull radio forward, disconnect the wire harness and antenna lead and remove radio.

DOUBLE ISO/DIN MOUNT INSTALLATION INSTRUCTIONS

1. Insert IMB-988 L&R into rear of kit & attach using 4 screws supplied w/kit.
2. Insert ISO mountable radio component(s) between ISO mount brackets from the rear and loosely attach to sides of radio using screws provided with radio when possible or hardware included with kit.
3. Slide radio component forward or backward for desired look and tighten screws.
4. Attach a rear support bracket to the rear of the new radio and adjust as necessary to support the weight of the audio/video component(s).

Insert ISO mounting brackets into radio opening, as shown in illustration, and attach radio to brackets using screws supplied with radio or kit.

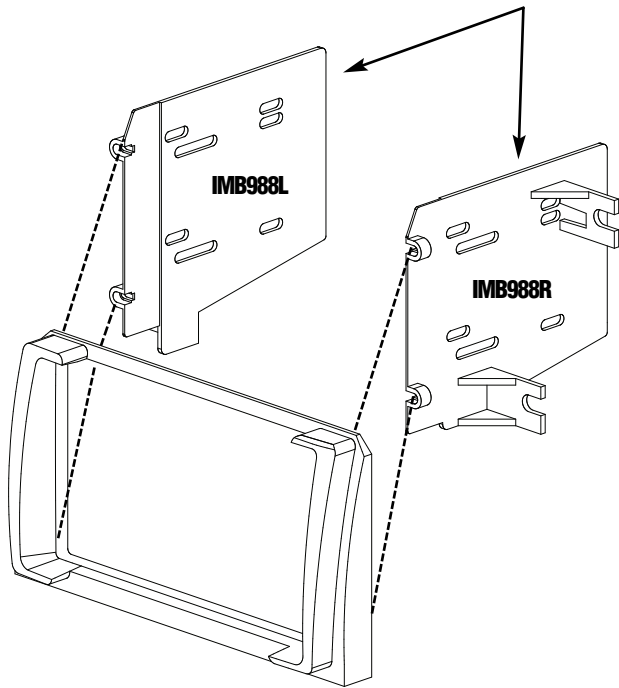

NOTES
