

For information about other American International automotive accessories visit our website at:

<http://www.americaninternational.net>

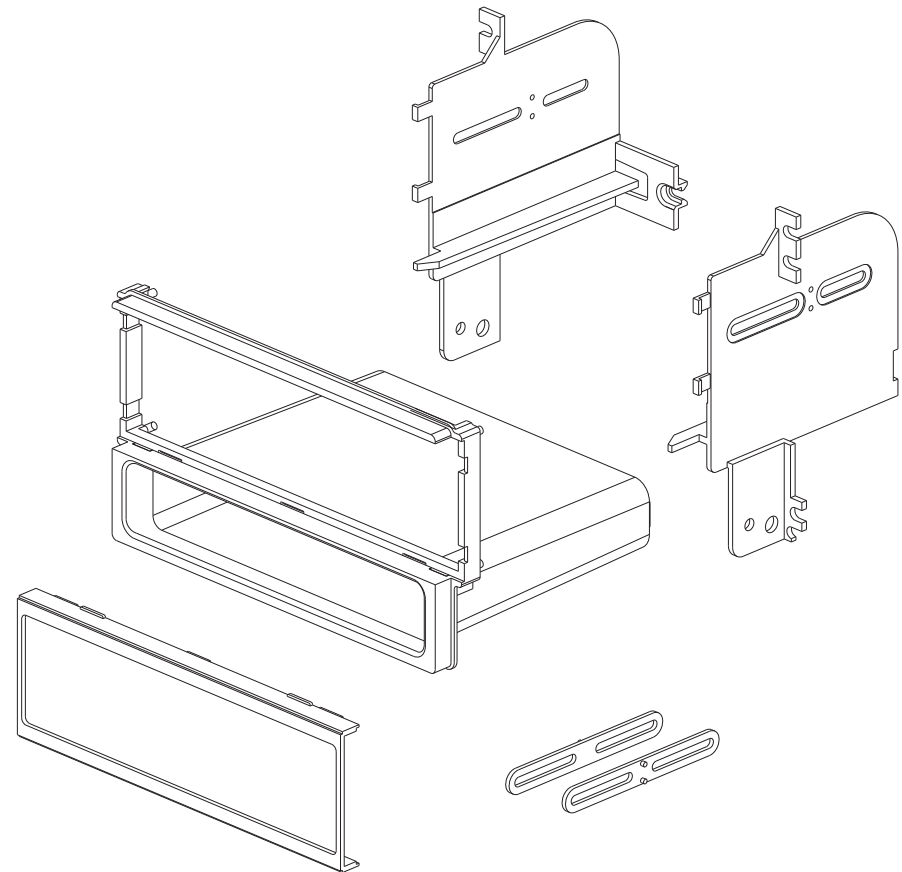

**American International**  
Car Stereo Installation Kits & Accessories



**HYN-K1124 Mounting Kit**



**American International**

**Automotive Products Division**

1040 Avenida Acaso • Camarillo, CA 93012, U.S.A.

USA Sales (800) 336-6500

Canada Sales (888) 922-3006 • USA Fax (805) 388-7950

**CUSTOMER HELP LINE**

8am-4:30 P.S.T. Monday-Friday Except Holidays

**USA 800-323-4329 • Canada 800-245-8777**

iHYNK1124

**VEHICLE APPLICATIONS**

**Hyundai**

2005-09 TUCSON

# HYUNDAI TUCSON INSTRUCTION UPDATE

## ATTENTION:

Disregard steps #13, #14 and #15 of the dash disassembly instructions for all vehicles that have the Climate Control module mounted directly to the back side of the Factory Radio dash trim Bezel.

Step # 2 of the kit assembly instructions is only required on vehicles with the Electronic Climate Control module attached directly to the radio mounting brackets. Disregard this step for all vehicles that have the Climate controls mounted directly to the back of the Factory Radio dash trim bezel.

### 2005-09 HYUNDAI TUCSON

## DASH DISASSEMBLY

1. Remove the small cover plate located on the lower rear side of the shift lever and remove the (2) Phillips screws then remove shifter knob.
2. Engage the emergency brake.
3. Carefully lift up on the shifter console trim, put key in ignition and turn to the on position (DO NOT START THE VEHICLE!)
4. Position the shift lever to the low position, pull upward on the console trim, disconnect the harness from the back of the shifter trim bezel and remove bezel.
5. Remove the (2) Phillips screws from the steel center crossbar that secures the center console shroud to the shifter base assembly.
6. Remove the (1) Phillips screw from each side of the lower edges of the Radio/Climate control trim bezel.
7. Remove the (1) Phillips screw from below the ashtray.
8. Remove the beauty covers and Phillips screws from each side of the lower forward sections of the center console base section.
9. Using a panel removal tool, remove the (1) panel fastener clip at the lower front section of the console.
10. Carefully pull the console trim back to allow radio/climate control trim bezel to be pulled outward.
11. Carefully pull radio/Climate control trim bezel forward, disconnect all harnesses from rear of bezel and remove bezel.
12. Remove (4) Phillips screws securing factory radio to sub-dash.
13. Remove (1) Phillips screw securing each side of the climate control to the sub-dash.
14. Carefully pull Radio and Climate control assembly forward, disconnect all harnesses and antenna lead and remove assembly.
15. Remove the (1) Phillips screw securing each side of the climate controls to the factory radio brackets and remove climate control unit. (These (2) factory screws will be used to attach the climate controls to the installation kit side brackets.)

## DIN MOUNT INSTRUCTIONS

1. Attach left and right mounting brackets to the kit as shown in Figure A and secure brackets to rear of pocket using screws provided in kit.
2. Insert the climate controls under the pocket and secure to the Left & Right mounting brackets using the same (2) screws removed in step (15) of Dash Disassembly instructions.
3. Insert DIN sleeve from your new radio into the radio opening of the installation kit.
4. Depress the tabs from inside the sleeves opening upward, outward, and downward to secure sleeve to the installation kit.

## ISO MOUNT INSTRUCTIONS

1. Attach left and right mounting brackets to the kit as shown in Figure A and secure brackets to rear of pocket using screws provided in kit.
2. Insert the climate controls under the pocket and secure to the Left & Right mounting brackets using the same (2) screws removed in step (15) of Dash Disassembly instructions.
3. Insert ISO mountable radio between ISO mount brackets and loosely attach to sides of radio using screws provided with radio when possible or screws supplied with kit.
4. Attach ISO trim ring to face of kit.
5. Slide radio forward or backward for desired look and tighten screws.

