

For information about other American International automotive accessories visit our website at:

<http://www.americaninternational.net>

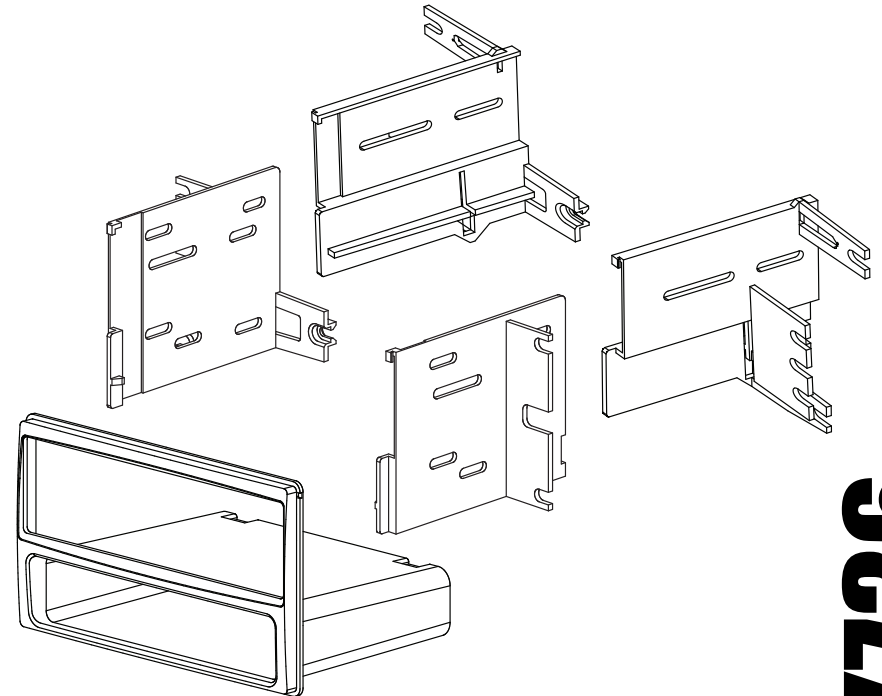

**American
International**
Car Stereo Installation Kits & Accessories



NDK736 Mounting Kit



American International

Automotive Products Division

1040 Avenida Acaso • Camarillo, CA 93012, U.S.A.

USA Sales (800) 336-6500

Canada Sales (888) 922-3006 • USA Fax (805) 388-7950

VEHICLE APPLICATIONS

Nissan

2009-13	CUBE
2007-14	VERSA SEDAN
2007-12	VERSA HATCHBACK (w/ Base CD Player)
2014	VERSA NOTE (w/ Base CD Player)

CUSTOMER HELP LINE

USA 800-323-4329 • Canada 800-245-8777

iNDK736

DASH DISASSEMBLY

1. Starting from the front, carefully pry up on the top dash vent trim and pull forward to remove.
2. Remove the (2) Phillips screws securing the top edge of the radio trim bezel.
3. Carefully pull the radio trim bezel forward, disconnect all attached harnesses from the back of the radio trim bezel and remove trim bezel.
4. Remove the (4) Phillips screws securing the factory radio to the sub-dash.
5. Carefully pull the radio forward, disconnect all harnesses and antenna connector and remove radio.

2009-13 NISSAN CUBE

DASH DISASSEMBLY

1. Remove the (2) Phillips screws (with plastic rings) securing the lower edge of the Climate Control panel.
2. Carefully unclip and lower out of the way the Climate Control panel.
3. Remove the (2) Phillips screws securing the lower edge of the Radio/Vent trim bezel to the sub-dash.
4. Carefully pry forward and unclip the lower edge of the Radio/Vent trim bezel and then unclip the top edge and remove the bezel.
5. Remove the (4) Phillips screws securing the radio to the sub-dash
6. Pull the radio forward, disconnect all harnesses and antenna lead and remove radio.

NISSAN VERSA (Use factory brackets for Double DIN)

KIT ASSEMBLY INSTRUCTIONS

1. This kit is an (ISO) mounting kit only. Remove metal sleeve from radio.
2. The mounting sleeve of your new radio and trim ring cannot be used when ISO mounting an aftermarket radio. Your radio must have a removeable trim ring.
3. Insert left and right mounting brackets to rear of kit as shown in Figure A and attach brackets to rear of pocket with small phillips screws supplied with kit.
4. Insert ISO mountable radio between ISO mount brackets and loosely attach to sides of radio using screws provided with radio when possible or screws supplied with kit.
5. Slide radio forward or backward for desired look and tighten screws.

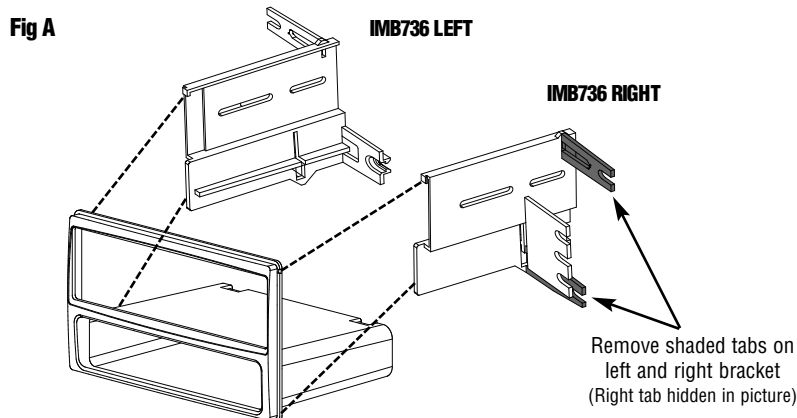

NOTES

NOTES

NISSAN CUBE

SINGLE ISO KIT ASSEMBLY INSTRUCTIONS

1. This kit is an (ISO) mounting kit only. Remove metal sleeve from radio.
2. The mounting sleeve of your new radio and trim ring cannot be used when ISO mounting an aftermarket radio. Your radio must have a removeable trim ring.
3. Insert left and right mounting brackets to rear of kit as shown in Figure B and attach brackets to rear of pocket with small phillips screws supplied with kit.
4. Insert ISO mountable radio between ISO mount brackets and loosely attach to sides of radio using screws provided with radio when possible or screws supplied with kit.
5. Slide radio forward or backward for desired look and tighten screws.

Fig B

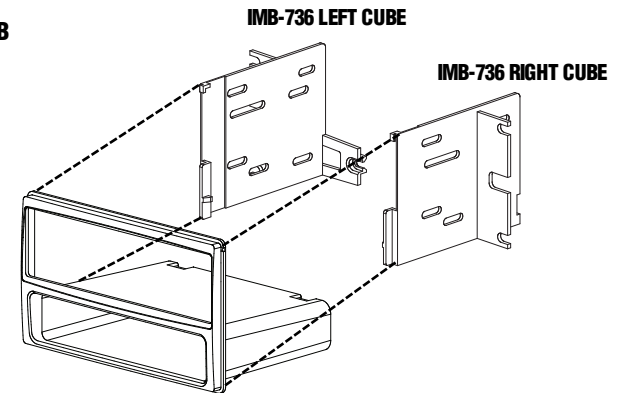

NISSAN CUBE

DOUBLE ISO/DOUBLE DIN KIT ASSEMBLY INSTRUCTIONS

1. Remove 3 shaded tabs on left and right Cube brackets as shown in Figure C below.
2. Insert ISO mountable radio between ISO mount brackets and loosely attach to sides of radio using screws provided with radio when possible or hardware included with kit.
3. Slide radio component forward or backward for desired look and tighten screws.
4. Attach a rear support bracket to the rear of the new radio and adjust as necessary to support the weight of the radio.

Fig C

