

For information about other American International  
automotive accessories visit our website at:

***<http://www.aius.net>***

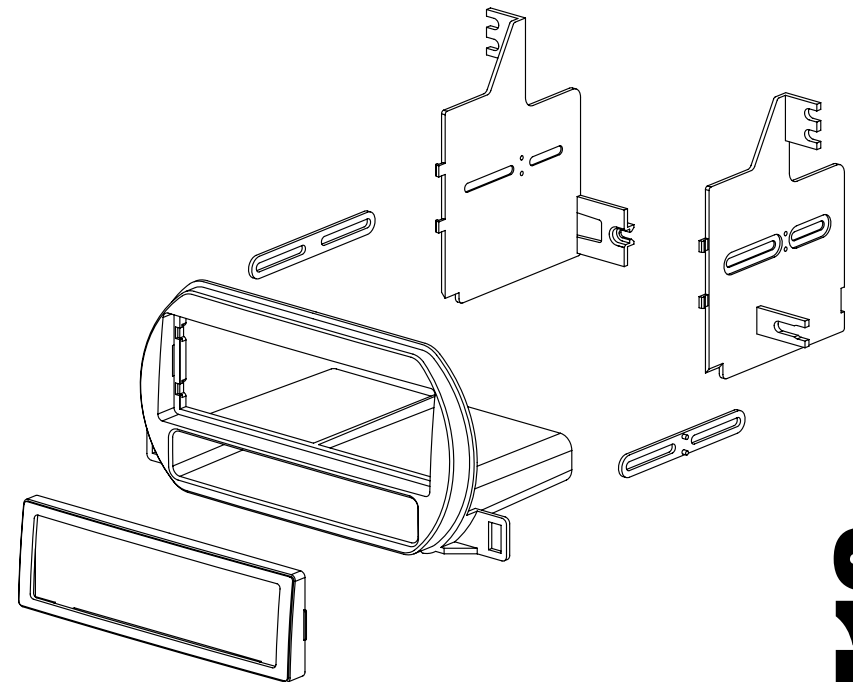

# NDK716 Mounting Kit



2500 East Francis Street Ontario, CA 91761, U.S.A.  
USA Sales (800) 336-6500  
Canada Sales (888) 922-3006

## VEHICLE APPLICATION

**Nissan**  
2002-04 ALTIMA

**CUSTOMER HELP LINE**  
USA 800-323-4329 • Canada 800-245-8777

## DASH DISASSEMBLY INSTRUCTIONS

1. Carefully remove the trim ring from around the Climate Controls, disconnect the Defroster harness and remove trim.
2. Remove the (1) Phillips screw from the lower right edge of the Radio dash trim bezel.
3. Carefully lift upward from the bottom of the radio trim bezel, pull Radio trim bezel forward and remove.
4. Remove the (4) Phillips screws securing the factory radio to the sub-dash.
5. Pull Radio forward, disconnect all harnesses and antenna lead from radio and remove radio.

## DIN MOUNT INSTRUCTIONS

1. Attach the left and right side brackets to the main bracket.
2. Attach left and right side brackets to the rear of the pocket using screws supplied.
3. Insert DIN sleeve from your new radio into the upper section of the installation kit. (This DIN sleeve comes with all new radios and slides off the back of the radio)
4. Depress the tabs from inside the sleeves opening upward, outward, and downward to secure sleeve to the installation kit.
5. Install radio into sleeve and lock into place.
6. Support rear of radio with back strap.

Optional use Trim Ring (ITR-716) may be used on some radios if desired.

Due to the movement of some faces on some radios our ISO Trim Ring may not be able to be used. You may also ISO mount your radio. See next page.

Your new radio must have a trim ring around the face of the radio that is designed to be easily removed. Consult your radio owner's manual.

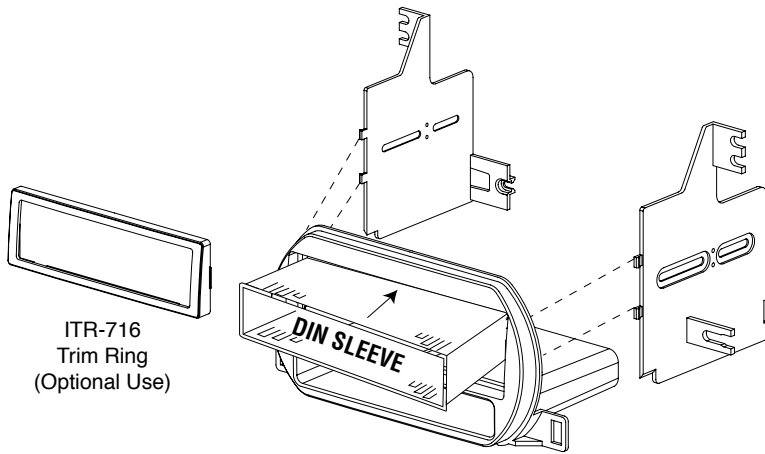

## KIT ASSEMBLY INSTRUCTIONS

**Note:** Some radio faces are larger in size than the ITR-716 Trim Ring allows.

You may need to file the Trim Ring opening larger for some radios.

1. Attach the left and right side brackets to the main bracket. See illustration below.
2. Attach left and right side brackets to the rear of the pocket using screws supplied w/kit.
3. Attach ISO Mount Spacers to the inside of upper section on both Left & Right mounting brackets as shown in Figure A below.
4. Slide radio into kit from rear & attach to ISO mounting brackets using screws supplied with radio (do not tighten screws at this time). (Be sure the length of the screws DO NOT touch any electrical parts inside radio, some screws may need to be shortened.)
5. Slide radio forward or backward for your desired look and then tighten the mounting screws. Use ISO trim ring when possible.
6. Attach rear support strap (supplied with radio) to rear of pocket and to rear of radio.

**NOTE:** Optional ISO trim ring (ITR-716 included) may be used in place of after-market radio's trim ring. For ISO mount applications, mount after-market radio to side brackets using hardware included.

