

## KIT ASSEMBLY INSTRUCTIONS

For all vehicles, excluding 2003-08 Hyundai Tiburon, remove the shaded tabs on the left and right sides of the kit as shown in illustration below.

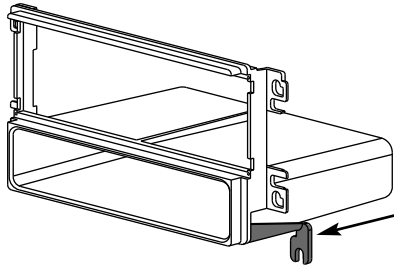

For vehicles with single ISO radio and factory pocket below the radio the steel crossbar in the sub-dash must be removed

Remove these brackets on left & right sides for:  
Elantra  
Santa Fe  
Sonata

**NOTE:** Kit may need to be moved slightly up or down for correct positioning to the subdash to allow dash trim bezel to fit over the kit.

For 2003-08 Hyundai Tiburon remove the shaded tabs on the left and right sides of the kit as shown in illustration below.

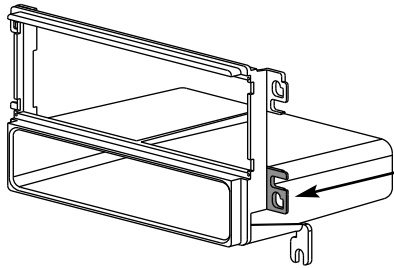

For vehicles with single ISO radio and factory pocket below the radio the steel crossbar in the sub-dash must be removed

Remove these brackets on left & right sides for tiburon applications

**NOTE:** Kit may need to be moved slightly up or down for correct positioning to the subdash to allow dash trim bezel to fit over the kit.

For information about other American International automotive accessories visit our website at:

**WWW.AIUS.NET**

2500 East Francis Street Ontario, CA 91761, U.S.A.

USA Sales (800) 336-6500

Canada Sales (888) 922-3006

**CUSTOMER HELP LINE**

**USA 800-323-4329 • Canada 800-245-8777**

iHYNK1118



**American  
International**  
Car Stereo Installation Kits & Accessories

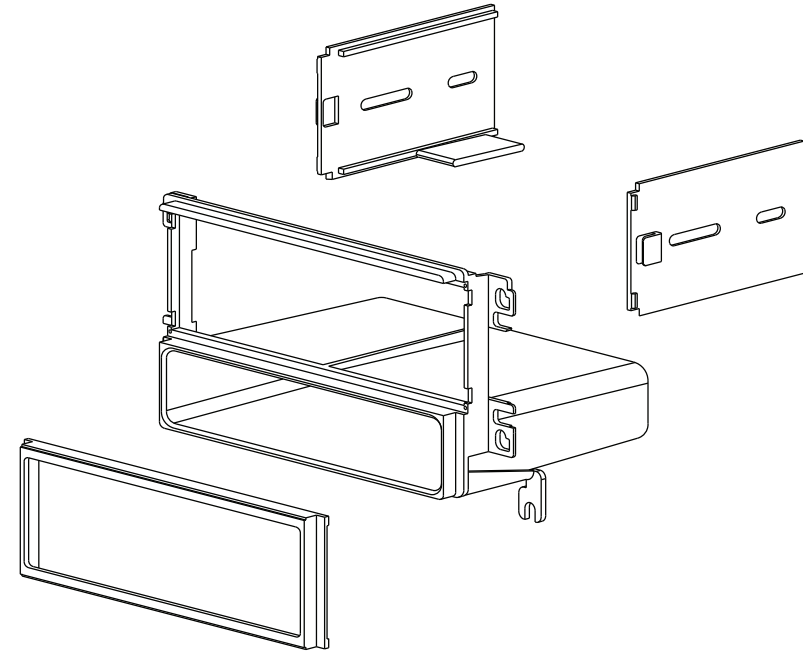

## VEHICLE APPLICATIONS

### HYUNDAI

2001-06 ELANTRA (OVERSIZED RADIO)

2001-06 SANTA FE (OVERSIZED RADIO)

2002-05 SONATA

2003-08 TIBURON

**HYNK1118 Mounting Kit**

## 2001-06 HYUNDAI ELANTRA

### DASH DISASSEMBLY

1. Remove the ashtray.
2. Remove the (2) phillips screws from the ashtray location.
3. Remove the (2) phillips screws from above the instrument gauges.
4. Lower the steering wheel all the way down.
5. Carefully remove the dash trim bezel from around the Radio/Climate controls.
6. Disconnect all harnesses from the Radio/Climate control trim bezel and remove the trim bezel.
7. Remove the (6) phillips screws securing the Radio to the sub-dash.
8. Pull the Radio forward, disconnect the wire harness and antenna lead from the radio and remove radio.

## 2001-06 HYUNDAI SANTA FE

### DASH DISASSEMBLY

1. Remove the ashtray.
2. Remove the (2) phillips screws from the ashtray location.
3. Carefully unsnap and pull forward the climate control unit.
4. Disconnect the harnesses from the climate control unit and remove climate control unit.
5. Remove the (2) phillips screws from the bottom edge of the Radio trim bezel.
6. Gently lift upward on the bottom edge of the radio trim bezel to release.
7. Gently pull the top of the radio trim bezel forward to release.
8. Disconnect all harnesses from the radio trim bezel and remove trim bezel.
9. Remove the (4) phillips screws securing the Radio to the sub-dash.
10. Pull the Radio forward, disconnect the wire harness and antenna lead and remove the radio.

## 2002-05 HYUNDAI SONATA

### DASH DISASSEMBLY

1. Open the ashtray.
2. Starting at the bottom, carefully unsnap the trim bezel around the radio.
3. Disconnect all harnesses from the climate controls, hazard button and clock and remove the trim bezel.
4. Remove the (4) phillips screws securing the radio to the sub-dash.
5. Pull the radio forward, disconnect the wire harness and antenna lead and remove the radio.

## 2003-08 HYUNDAI TIBURON

### DASH DISASSEMBLY

1. Open the ashtray.
2. Carefully pull outward on the lower portion of the dash trim bezel / climate control panel to unclip the lower edge.
3. Continue to carefully pry outward from the sides going upward on the trim bezel / climate control panel to unfasten the side and top clips and pull the dash trim/climate control panel forward.
4. Disconnect all harnesses connected to the buttons and climate controls and remove the panel.
5. Remove the (4) Phillips screws securing the radio to the sub-dash and pull radio forward.
6. Disconnect the wire harness and antenna lead from the radio and remove radio.

## RADIO & KIT INSTALLATION INSTRUCTIONS

### ISO MOUNT

1. Attach the left and right ISO mount brackets to the kit. (See illustration below.)
2. Slide the radio in to the kit from the rear and attach the radio to the mounting brackets using the screws supplied with your new radio. (Do NOT tighten screws.)
3. Attach the ISO trim ring to the front of the installation kit.
4. Adjust the radio forward or backward for desired look, and tighten the ISO mounting screws.

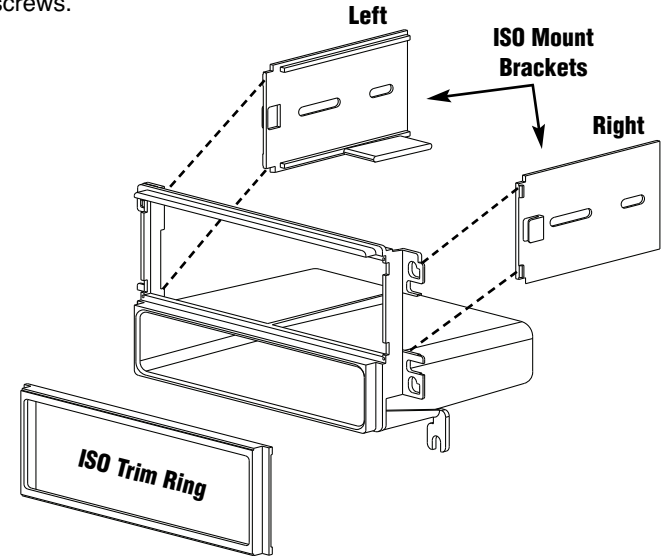

### DIN MOUNT

#### Do not attach the ISO Brackets

1. Slide the metal sleeve from your new radio into the installation kit and bend the tabs on the sleeve upward, outward, and downward to secure the sleeve to the kit.

**NOTE:** The ISO trim ring included in this kit must be used in place of the aftermarket Radio's trim ring if the aftermarket radio's trim ring is removable. (See your owner's manual for radio trim ring removal instructions.)

