

For information about other American International automotive accessories visit our website at:

<http://www.americaninternational.net>

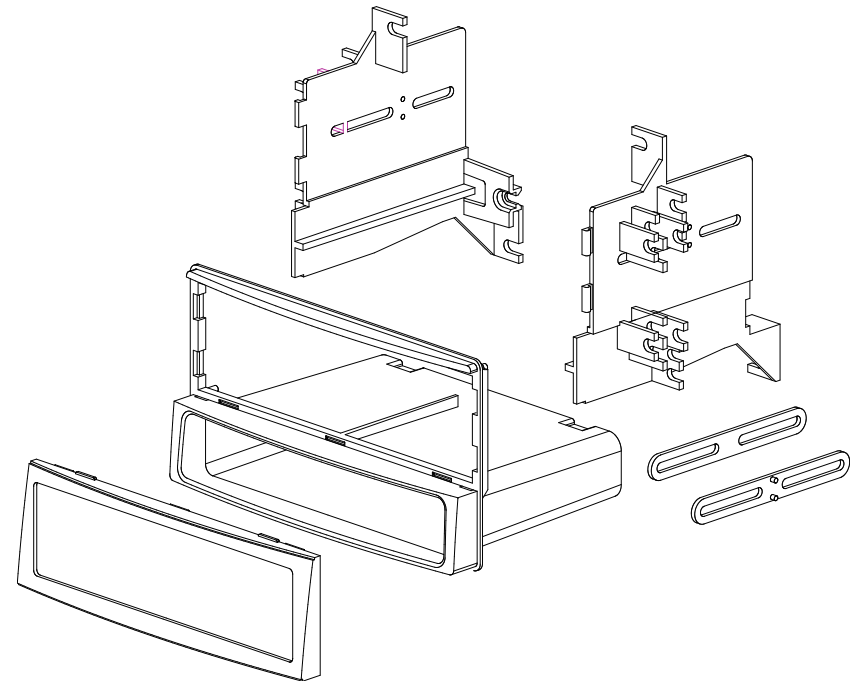

**American
International**
Car Stereo Installation Kits & Accessories



KIAK1246 Mounting Kit



American International

Automotive Products Division

1040 Avenida Acaso • Camarillo, CA 93012, U.S.A.

USA Sales (800) 336-6500

Canada Sales (888) 922-3006 • USA Fax (805) 388-7950

CUSTOMER HELP LINE

USA 800-323-4329 • Canada 800-245-8777

iKIAK1246

VEHICLE APPLICATIONS

Hyundai

2007-09 ENTOURAGE

Kia

2006-10 OPTIMA

2006-12 SEDONA

2004-09 SPECTRA

2005-08 SPECTRA 5

2007-10 RONDO

BRACKET PREPARATION

2007-09 KIA SPECTRA / SPECTRA 5

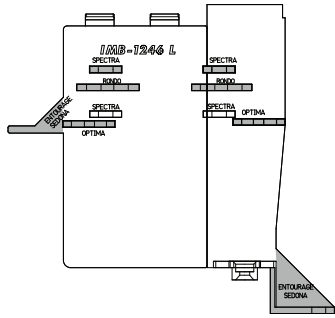

LEFT BRACKET

REMOVE ALL
SHADED TABS ON
L&R BRACKETS

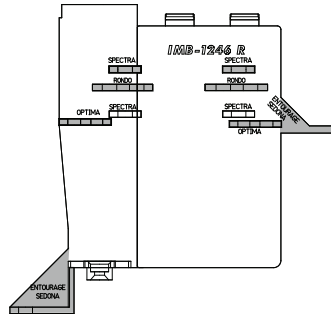

RIGHT BRACKET

2007-10 KIA ROND

REMOVE ALL
SHADED TABS ON
L&R BRACKETS

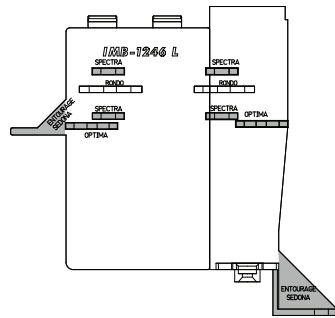

LEFT BRACKET

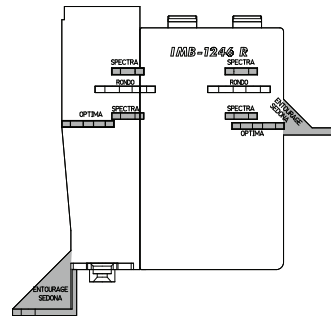

RIGHT BRACKET

KIT ASSEMBLY INSTRUCTIONS - ALL MODELS

1. See page 5-6 for Bracket Preparation.
2. Attach the left and right side brackets to the main bracket.
3. Attach left and right side brackets to the rear of the pocket using small screws supplied with kit.

DIN MOUNT INSTRUCTIONS

1. See page 5-6 for Bracket Preparation.
2. Attach the left and right side brackets to the main bracket. See illustration below.
3. Attach left and right side brackets to the rear of the pocket using screws supplied w/kit.
4. Insert DIN sleeve from your new radio into the upper section of the installation kit.
5. Depress the tabs from inside the sleeves opening upward, outward, and downward to secure sleeve to the installation kit.
6. Install radio into sleeve and lock into place.
7. Support rear of radio with back strap.

Optional use Trim Ring (ITR-1246) may be used on some radios if desired.

Due to the movement of some faces on some radios our ISO Trim Ring may not be able to be used. You may also ISO mount your radio. See page 4.

Your new radio must have a trim ring around the face of the radio that is designed to be easily removed. Consult your radio owner's manual.

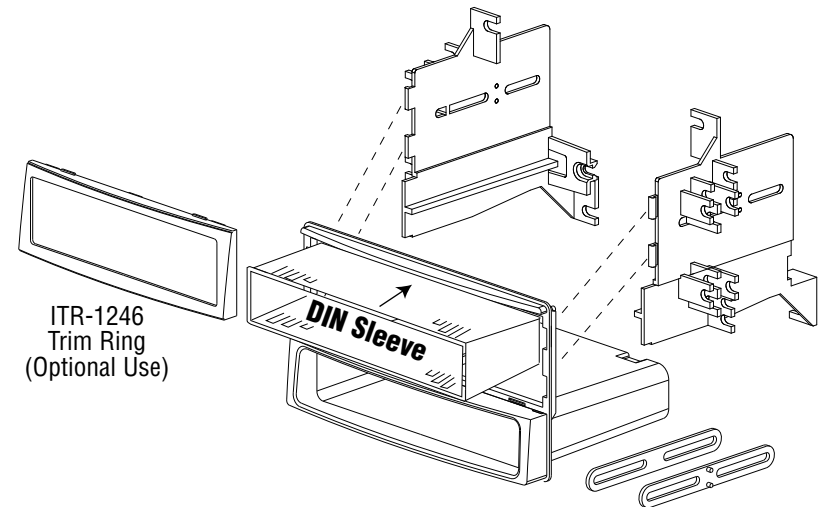

ISO MOUNT INSTALLATION INSTRUCTIONS

Note: Some radio faces are larger in size than the ITR-1246 Trim Ring allows. You may need to file the Trim Ring opening larger for some radios.

1. See page 5-6 for Bracket Preparation.
2. Attach the left and right side brackets to the main bracket. See illustration below.
3. Attach left and right side brackets to the rear of the pocket using screws supplied w/kit.
4. Attach ISO Mount Spacers to the inside of upper section on both Left & Right mounting brackets as shown in Figure A below.
5. Slide radio into kit from rear & attach to ISO mounting brackets using screws supplied with radio (do not tighten screws at this time). (Be sure the length of the screws DO NOT touch any electrical parts inside radio, some screws may need to be shortened.)
6. Slide radio forward or backward for your desired look and then tighten the mounting screws. Use ISO trim ring when possible.
7. Attach rear support strap (supplied with radio) to rear of pocket and to rear of radio.

NOTE: Optional ISO trim ring (ITR-1246 included) may be used in place of after-market radio's trim ring. For ISO mount applications, mount after-market radio to side brackets using hardware included.

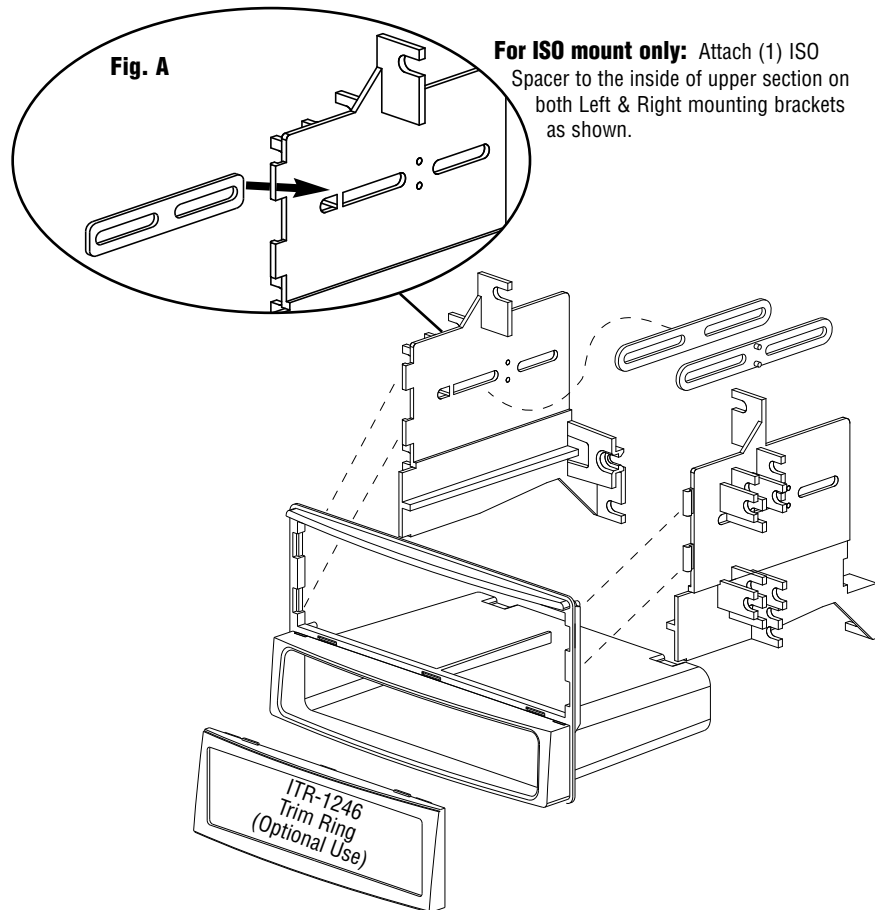

BRACKET PREPARATION

2006-10 KIA OPTIMA

REMOVE ALL
SHADED TABS ON
L&R BRACKETS

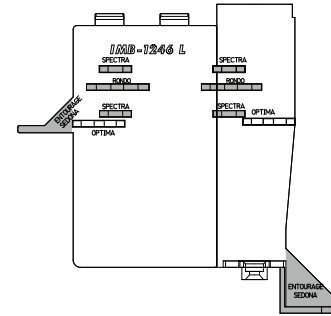

LEFT BRACKET

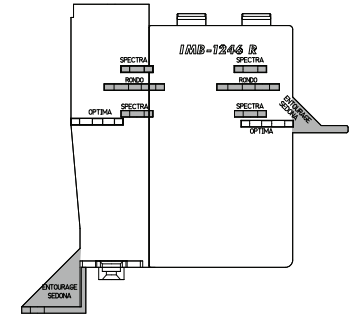

RIGHT BRACKET

2004-06 KIA SPECTRA / SPECTRA 5

REMOVE ALL
SHADED TABS ON
L&R BRACKETS

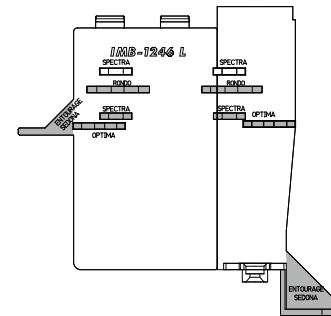

LEFT BRACKET

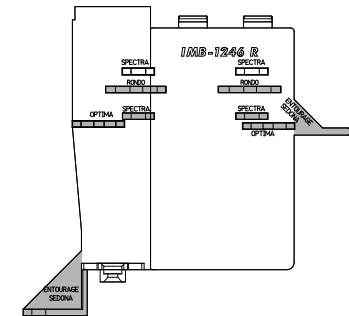

RIGHT BRACKET

2007-09 HYUNDAI ENTOURAGE
2006-12 KIA SEDONA

REMOVE ALL
SHADED TABS ON
L&R BRACKETS

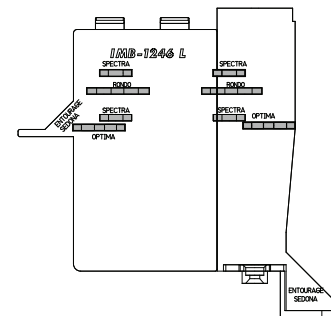

LEFT BRACKET

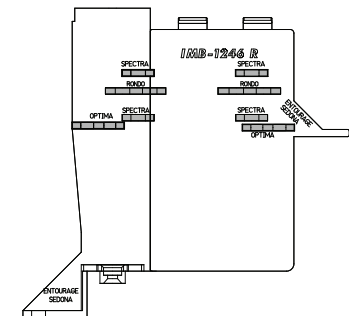

RIGHT BRACKET