

For information about other American International automotive accessories visit our website at:

<http://www.americaninternational.net>

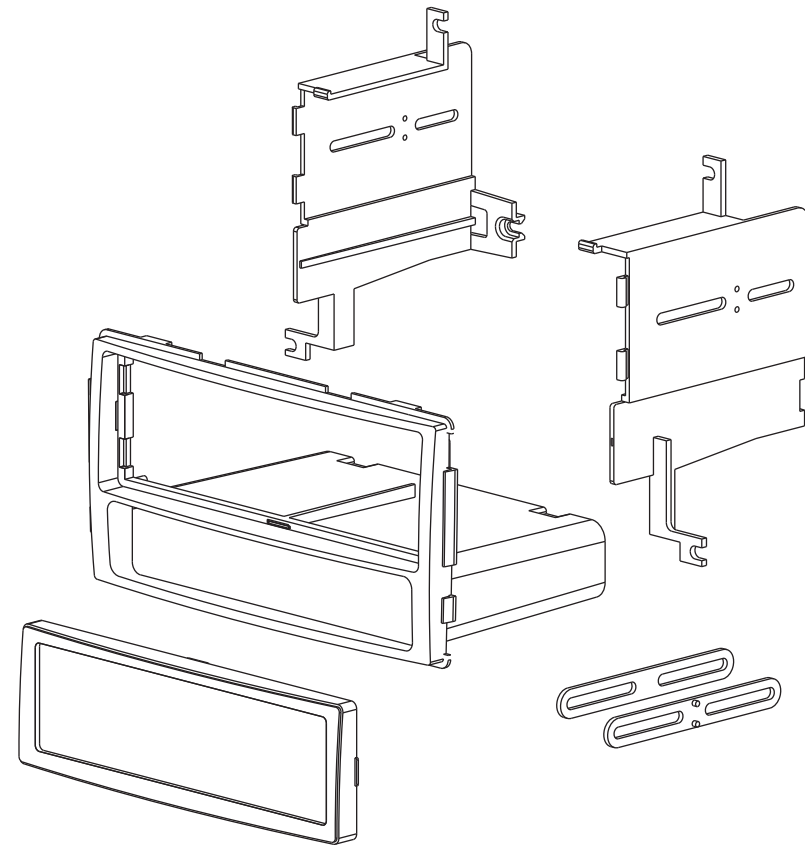

**American International**  
Car Stereo Installation Kits & Accessories



**HYN-K1130 Mounting Kit**



**American International**

**Automotive Products Division**

1040 Avenida Acaso • Camarillo, CA 93012, U.S.A.

USA Sales (800) 336-6500

Canada Sales (888) 922-3006 • USA Fax (805) 388-7950

**VEHICLE APPLICATIONS**

Hyundai  
2007 SANTA FE

**CUSTOMER HELP LINE**  
USA 800-323-4329 • Canada 800-245-8777

iHYNK1130

## DASH DISASSEMBLY

1. Open the storage pocket above the radio and remove the (2) Phillips screws from the front edge.
2. Open the driver's door and remove the side dash cover plate exposing (2) Phillips screws that secure the driver's knee pad cover.
3. Remove the (2) Phillips screws securing the lower edge of the driver's side knee pad cover, carefully pull knee pad cover outward and remove knee pad cover.
4. Carefully unclip and pull forward and remove the trim that extends from the ignition to just above the glove box.
5. Remove the (2) Phillips screws from the bottom edge of the Radio/Vent trim assembly, pull the trim assembly forward, disconnect all harnesses attached to the rear of the trim assembly and remove trim assembly.
6. Remove the (4) Phillips screws securing the radio to the sub-dash, pull radio forward and disconnect all harnesses and antenna lead and remove radio.

## KIT ASSEMBLY INSTRUCTIONS

1. Attach the left and right side brackets to the main bracket.
2. Attach left and right side brackets to the rear of the pocket using small screws supplied with kit.

## DIN MOUNT INSTRUCTIONS

1. Insert DIN sleeve from your new radio into the upper section of the installation kit. (This DIN sleeve comes with all new radios and slides off the back of the radio)
2. Depress the tabs from inside the sleeves opening upward, outward, and downward to secure sleeve to the installation kit.
3. Install radio into sleeve and lock into place.
4. Support rear of radio with back strap.

Optional use Trim Ring (ITR-1130) may be used on some radios if desired.

Due to the movement of some faces on some radios our ISO Trim Ring may not be able to be used. You may also ISO mount your radio. See page 4.

Your new radio must have a trim ring around the face of the radio that is designed to be easily removed. Consult your radio owner's manual.

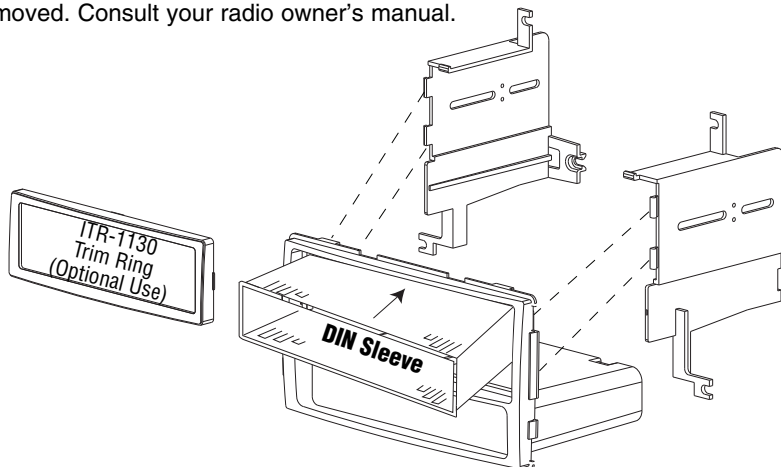

## ISO MOUNT INSTALLATION INSTRUCTIONS

**Note:** Some radio faces are larger in size than the ITR-1130 Trim Ring allows. You may need to file the Trim Ring opening larger for some radios.

1. Attach the left and right side brackets to the main bracket. See illustration below.
2. Attach left and right side brackets to the rear of the pocket using screws supplied w/kit.
3. Attach ISO Mount Spacers to the inside of upper section on both Left & Right mounting brackets as shown in Figure A below.
4. Slide radio into kit from rear & attach to ISO mounting brackets using screws supplied with radio (do not tighten screws at this time). (Be sure the length of the screws DO NOT touch any electrical parts inside radio, some screws may need to be shortened.)
5. Slide radio forward or backward for your desired look and then tighten the mounting screws. Use ISO trim ring when possible.
6. Attach rear support strap (supplied with radio) to rear of pocket and to rear of radio.

**NOTE:** Optional ISO trim ring (ITR-1130 included) may be used in place of after-market radio's trim ring. For ISO mount applications, mount after-market radio to side brackets using hardware included.

